

# Service Manual

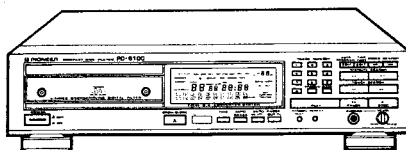

ORDER NO.  
ARP1570

COMPACT DISC PLAYER

# PD-6100

## PD-6100-S

MODEL PD-6100 AND PD-6100-S HAVE THREE VERSIONS :

TYPE	Applicable model		Power requirement	Export destination
	PD-6100	PD-6100-S		
HEM	○	○	AC220V, 240V (switchable) *	European continent
HB	○	—	AC220V, 240V (switchable) *	United Kingdom
SD	○	—	AC110V, 120V-127V, 220V, 240V (switchable)	Kingdom of Saudi Arabia and General market

\* Change the primary wiring of the power transformer.

- This manual is applicable to the HEM, HB and SD types.
- For the HB, SD and PD-6100-S/HEM types, refer to page 84.
- The PD-6100-S is the same as the PD-6100 except for the color.
- Ce manuel pour le service comprend les explications en français de réglage.
- Este manual de servicio trata del método ajuste escrito en español.

## CONTENTS

1. SAFETY INFORMATION.....	2	9. ELECTRICAL PARTS LIST.....	32
2. SPECIFICATIONS .....	4	10. ADJUSTMENTS.....	35
3. PANEL FACILITIES.....	5	10. REGLAGE.....	50
4. EXPLODED VIEWS AND PARTS LIST .....	9	10. AJUSTE.....	65
5. SCHEMATIC DIAGRAM .....	15	11. IC DESCRIPTIONS.....	80
6. BLOCK DIAGRAM .....	22	12. REMOTE CONTROL UNIT .....	83
7. P.C. BOARDS CONNECTION DIAGRAM.....	25	13. FOR HB, SD, AND	
8. PACKING.....	31	PD-6100-S/HEM TYPES.....	84

**PIONEER ELECTRONIC CORPORATION** 4-1, Meguro 1-Chome, Meguro-ku, Tokyo 153, Japan  
**PIONEER ELECTRONICS SERVICE INC.** P.O. Box 1760, Long Beach, California 90801 U.S.A.  
**PIONEER ELECTRONICS OF CANADA, INC.** 505 Cochrane Drive, Markham, Ontario L3R 8E3 Canada  
**PIONEER ELECTRONIC [EUROPE] N.V.** Keetberglaan 1, 2740 Beveren, Belgium  
**PIONEER ELECTRONICS AUSTRALIA PTY. LTD.** 178-184 Boundary Road, Braeside, Victoria 3195, Australia TEL: [03] 580-9911

# 1. SAFETY INFORMATION

## 1. SAFETY PRECAUTIONS

The following check should be performed for the continued protection of the customer and service technician.

### LEAKAGE CURRENT CHECK

Measure leakage current to a known earth ground (water pipe, conduit, etc.) by connecting a leakage current tester such as Simpson Model 229-2 or equivalent between the earth ground and all exposed metal parts of the appliance (input/output terminals, screwheads, metal overlays, control shaft, etc.). Plug the AC line cord of the appliance directly into a 120V AC 60Hz outlet and turn the AC power switch on. Any current measured must not exceed 0.5mA.

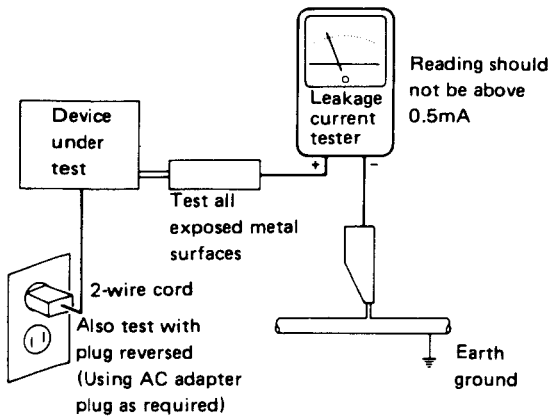

AC Leakage Test

ANY MEASUREMENTS NOT WITHIN THE LIMITS OUTLINED ABOVE ARE INDICATIVE OF A POTENTIAL SHOCK HAZARD AND MUST BE CORRECTED BEFORE RETURNING THE APPLIANCE TO THE CUSTOMER.

## 2. PRODUCT SAFETY NOTICE

Many electrical and mechanical parts in the appliance have special safety related characteristics. These are often not evident from visual inspection nor the protection afforded by them necessarily can be obtained by using replacement components rated for voltage, wattage, etc. Replacement parts which have these special safety characteristics are identified in this Service Manual.

Electrical components having such features are identified by marking with a ⚠ on the schematics and on the parts list in this Service Manual.

The use of a substitute replacement component which does not have the same safety characteristics as the PIONEER recommended replacement one, shown in the parts list in this Service Manual, may create shock, fire, or other hazards.

Product Safety is continuously under review and new instructions are issued from time to time. For the latest information, always consult the current PIONEER Service Manual. A subscription to, or additional copies of, PIONEER Service Manual may be obtained at a nominal charge from PIONEER.

(FOR EUROPEAN MODEL ONLY)

**VAROITUS!**  
LAITE SISÄLTÄÄ LASERDIODIN, JOKA LÄHETTÄÄ NÄKYMÄTÖNTÄ, SILMILLE VAARALLISTA INFRAPUNASATEILYLA LAITTEEN SISÄLLÄ ON LASERDIODIN LAHEISYYDESSÄ KUVA 1. MUKAINEN VAROITUSMERKKI.



LASER  
Kuva 1  
Lasersateilyn  
varoituserkki

**WARNING!**  
DEVICE INCLUDES LASER DIODE WHICH EMITS INVISIBLE INFRARED RADIATION WHICH IS DANGEROUS TO EYES. THERE IS A WARNING SIGN ACCORDING TO PICTURE 1 INSIDE THE DEVICE CLOSE TO THE LASER DIODE.



LASER  
Picture 1  
Warning sign for  
laser radiation

**ADVERSEL:**  
USYNLIG LASERSTRÅLING VED ÅBNING NÅR SIKKERHEDSAFBRYDERE ER UDE AF FUNKTION UDGÅ UDSAETTELSE FOR STRÅLING.

**VIKTIGT**  
APARATEN INNEHÅLLER LASER AV HÖGRE KLASS ÄN 1. INGREPP I APPARATEN BÖR GÖRAS AV SPECIELLT UTBILDAD PERSONAL.

**IMPORTANT**  
PIONEER COMPACT DISC PLAYER APPARATUS CONTAINS LASER OF HIGHER CLASS THAN 1. SERVICING OPERATION OF THE APPARATUS SHOULD BE DONE BY A SPECIALLY INSTRUCTED PERSON.

**LABEL CHECK**

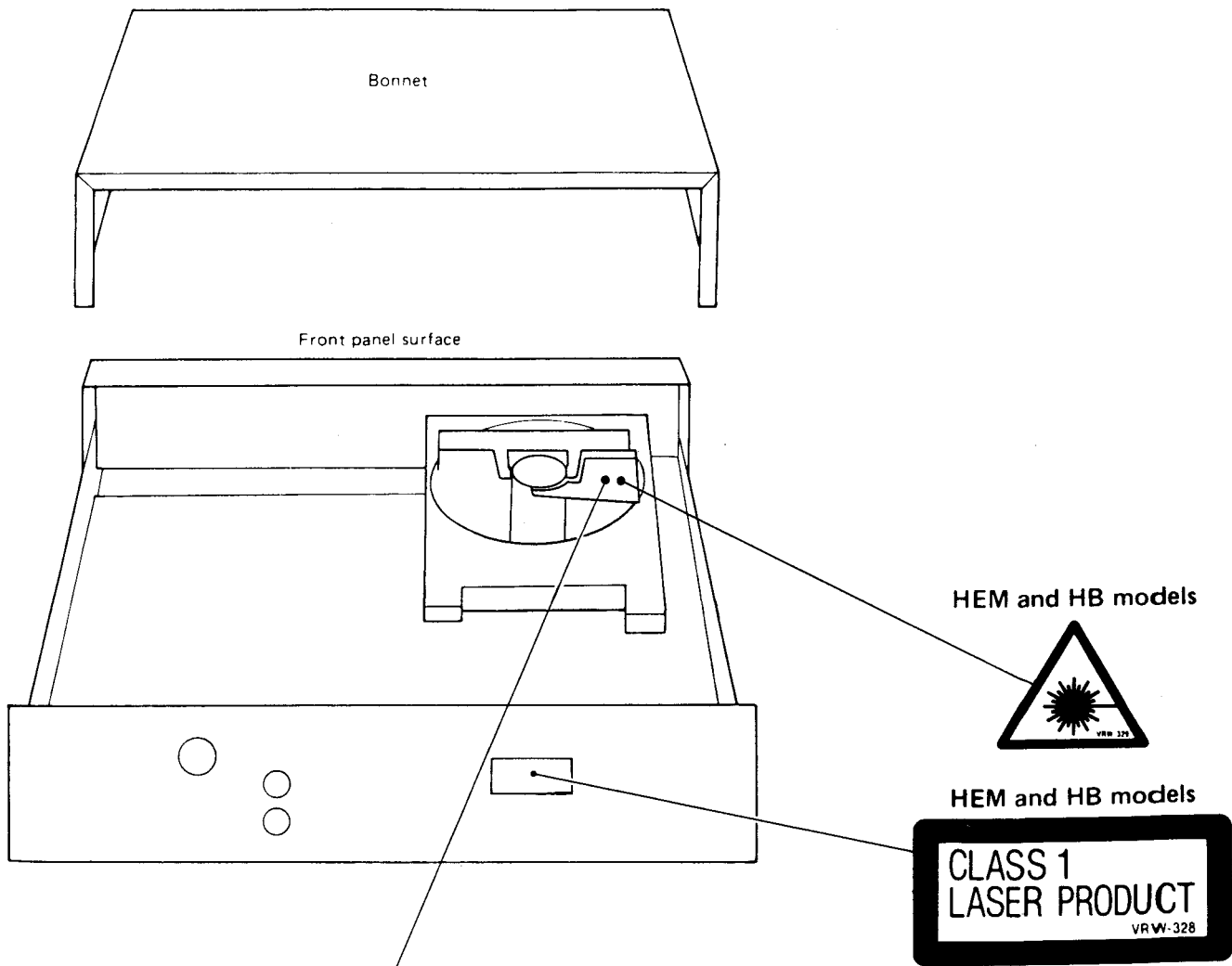

**HB model**

**CAUTION**  
**INVISIBLE LASER RADIATION WHEN OPEN, AVOID EXPOSURE TO BEAM**  
 PRW1018

**HEM model**

CAUTION  
 LASER RADIATION WHEN OPEN. AVOID EXPOSURE TO BEAM.  
 ADVARSEL  
 FARE FOR USYNLIG LASERSTRÅLING VED ÅBNING AF DÆKSEL.  
 UNDGÅ AT UDSETTE ØJENE FOR STRÅLING.  
 VORSICHT!  
 UNSICHTBARE LASER-STRÄHLUNG TRITT AUS, WENN DECKEL  
 (ODER KLAPPE) GEOFFNET IST! NICHT DEM STRAHL AUSSETZEN!  
 PRW-175

**ADDITIONAL LASER PRECAUTIONS**

- 1. Laser Interlock Mechanism**

The clamp switch (S102) detects the completion of the Load in operation, and the ON/OFF status of the clamp switch is in turn detected by the microcomputer. The Laser diode is designed not to oscillate while the clamp switch is in OFF status. Consequently, if S102 is accidentally short-circuited, the interlock mechanism will become incapable of operation.

Moreover, when short-circuiting occurs between Pins 4 or 5 of CXA1081S (IC 1) and GND, or between Pin 29 of CXA1081S (IC 1) and GND, or between the terminals of Q1 (a Fault Condition will occur in all three cases), the laser diode will oscillate continuously. Note that during TEST Mode (see page 35), the interlock mechanism does not operate.
- 2. While the bonnet is in opened status, if the pickup is positioned to allow direct visibility of the objective lens at the outer periphery from the outer diameter of the disc clumper (80-mm diameter), the pickup can be flooded with radiation of more than class 1 of the laser optical system during any Fault Condition in Item 1 above or during TEST Mode.**

## 2. SPECIFICATIONS

### 1. General

Type ..... Compact disc digital audio system  
 Usable discs ..... Compact Disc  
 Signal format ..... Sampling frequency: 44.1kHz  
 Quantized bit number: 16 bit linear

#### Power requirements

European models ..... AC 220V, 50/60Hz  
 U.K., Australian models ..... AC 240V, 50/60Hz  
 U.S., Canadian models ..... AC 120V, 60Hz  
 Other models ..... AC 110/120–127/220/240V  
 (switchable), 50/60Hz

Power consumption ..... 16W  
 Operating temperature ..... +5°C – +35°C  
 (+41°F – +95°F)

Weight ..... 4.0kg (8lb, 13oz)  
 External dimensions ..... 420(W) × 315(D) × 98(H)mm  
 16-1/2(W) × 12-3/8(D) × 3-7/8(H) in.

### 2. Audio section

Frequency response ..... 4Hz–20kHz (±0.5dB) (EIAJ)  
 S/N ..... 104dB or more (EIAJ)  
 Dynamic range ..... 96dB or more (EIAJ)  
 Channel separation ..... 100dB or more (EIAJ)  
 Total harmonic distortion ..... 0.0035% or less (EIAJ)  
 Output voltage ..... 2.2V ± 0.3V (EIAJ)  
 Wow and flutter ..... Limit of measurement  
 (±0.001% W.PEAK) or less (EIAJ)

Number of channels ..... 2 channels (stereo)  
 Digital output ..... Coaxial output: 0.5Vp-p (75Ω)

### 3. Output terminal

Audio line output terminal  
 Coaxial digital output terminal  
 Headphone jack (with volume control)

### 4. Functions

- Play
- Pause
- Manual search
- Track search
- Index search
- Direct track search
- One track repeat
- All track repeat
- Programmed repeat
- Programmed playback
- Pause program
- Add-on program
- Auto program editing
- Time fade editing
- Random play
- Random play repeat
- Auto space
- Digital level control (remote control)
- Timer start
- One touch fade-in and fade-out

### 5. Accessories

- Remote control unit ..... 1
- Size AAA/R03 dry cell batteries ..... 2
- Output cable ..... 1
- Operating instructions ..... 1

#### NOTE:

*The specifications and design of this product are subject to change without notice, due to improvements.*

### 3. PANEL FACILITIES

#### FRONT PANEL

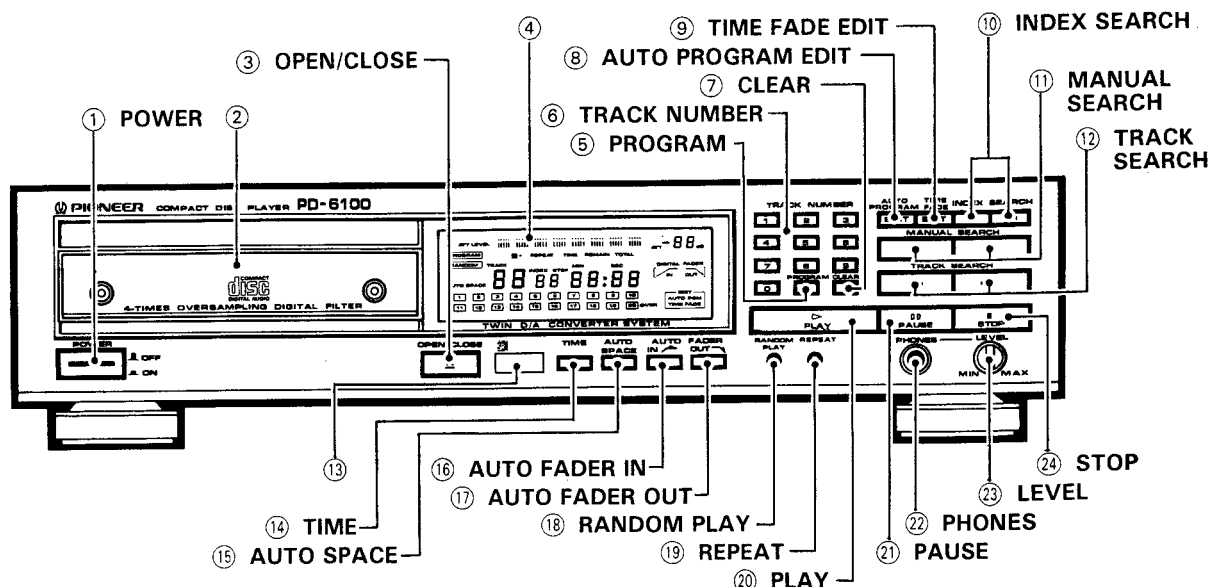

① **POWER switch**

Press to turn power to the unit ON and OFF.  
If there is a disc in the unit when power is turned ON, playback will begin automatically. (Timer start function)

② **Disc Tray**

This is where the disc is set. When power is switched ON and the OPEN/CLOSE key is pressed, the tray is ejected forward. To insert the tray, press the OPEN/CLOSE key, or lightly push the tray in with your finger. With the disc tray open, pressing the PLAY key will close the disc tray and start playback.

③ **OPEN/CLOSE key (▲)**

Press when you wish to eject or load a disc. Each time the key is pressed, the tray is alternately pushed out or pulled in.

④ **Indicators**

- ATT LEVEL : The volume level of fade-in, fade-out, and output level is displayed.
- PROGRAM : Lights after programming (after program has been memorized).
- -REPEAT : Lights during repeat playback of one track.
- REPEAT : Lights during repeat playback.
- RANDOM : Lights during random playback.
- AUTO SPACE : Lights during auto space playback.
- TRACK
- [1] - [20], OVER (Music calendar) : Displays the current track number (during normal playback and programmed playback) or the track being programmed during programming operation. The lower figures light up in accordance with the number of tracks recorded on the disc, and the numbers of the tracks which have been played are deleted in order. (During programmed playback only the programmed tracks light.) For 21 or over, OVER will light.

- INDEX : Displays the index \* number of the music section of a track or the track division.
- STEP : Displays the program steps.
- MIN (minute) : Displays the minutes of the elapsed time, total playback time, and remaining time.
- SEC (second) : Displays the seconds of the elapsed time, total playback time, and remaining time.
- TIME/REMAIN/TOTAL : Changes each time the TIME key is pressed.
  - TIME : Displays the track number of the track being played (TRACK) and the elapsed time (minutes and seconds).
  - REMAIN : Displays the remaining time on the track being played. When the TIME key is pressed again, the remaining time on the disc will be displayed.
  - TOTAL : Displays the total number of tracks on the disc (TRACK) and the overall playback time (minutes and seconds). During playback, the display goes on for about 5 seconds before changing to the TIME display.

Programmed playback operation displays the remaining time of the programmed tracks (REMAIN), and the total playback time (TOTAL).

- IN : Lights during fade-in.
- OUT : Lights during fade-out.
- ATT : The volume level of fade-in, fade-out, and output level is displayed by decreasing level (-dB).
- AUTO PGM EDIT : Displays when Auto Program Editing is set or used.
- TIME FADE EDIT : Displays when Time Fade Editing is set or used.

\* The INDEX is a signal which is recorded within a track to indicate division of the track into separate turns and items of music.

⑤ **PROGRAM key (program memory)**

Use to program a sequence of tracks.

- Press this key after selecting a desired track with the track number keys. Tracks will be added to the program in the order in which they are selected.

⑥ **TRACK NUMBER keys (1 to 0)**

- Use to specify track numbers (track 1—track 99) for selection of tracks or program entry.
- Use to specify time (in minutes), during auto program editing and time fade editing.

⑦ **CLEAR key**

Press this key to clear the program.

⑧ **AUTO PROGRAM EDIT key**

Press to program a tune which may be played back within a specified time.

⑨ **TIME FADE EDIT key**

Press this key to end playback at a desired time with fade-out.

⑩ **INDEX SEARCH keys**

Searches, during playback or pause, for the music section of a track or the track index. When pressed, the unit will return to the previous index or advance to the next index.

[▷▷] : Advances to the next index number.

[◀◀] : Returns to the index number of the currently-playing music section or track.

⑪ **MANUAL SEARCH keys**

When the player is in playback or pause modes, these keys are pressed to perform fast forward or reverse operations to allow manual searching. These operations are only carried out during the time either key is pressed.

[▶▶] : For fast forward operation. If the end of the disc is reached during fast forward operation, "End" will be displayed and the player will enter the pause mode. [During programmed playback, the player will enter the pause mode right before it reaches the next track (program step).]

[◀◀] : For fast reverse operation. If the beginning of the disc is reached during fast reverse operation, the player will enter the playback mode. [During programmed playback, the player will enter the playback mode right before it reaches the previous track (program step).]

⑫ **TRACK SEARCH keys**

During normal playback, programmed playback or pause modes, these keys are pressed to search for the desired track. Pressing either key causes the player to advance to the next track or to return to the previous track. Even in stop mode, these keys can be used to select the desired track. Press the PLAY key to playback the desired track.

[▶▶] : When pressed once, playback advances to the beginning of the next track on the disc; when pressed continuously, playback advances to the beginning of succeeding tracks on the disc. (During programmed playback, it advances to the beginning of the next programmed track.)

[◀◀] : When pressed once, playback returns to the beginning of the currently playing track; when pressed continuously, playback shifts to the beginning of previous tracks on the disc. (During programmed playback it returns to the beginning of the previous programmed track.)

⑬ **Remote sensor**

⑭ **TIME key**

This key selects the display mode of the indicator panel. Each time the key is pressed, the indication changes from TIME, REMAIN, to TOTAL in that order. (For details concerning the display contents, refer to the explanation about the indicators.)

If pressed after pressing the track number key, the playback time of the selected track only is displayed.

⑮ **AUTO SPACE key**

During playback, there will be a pause of about three seconds before the next track is played.

⑯ **AUTO FADER IN key**

Press this key to start playback with fade-in sound. (Possible only in pause mode during playback.)

⑰ **AUTO FADER OUT key**

Press this key for fade-out sound. (After fade-out is completed, the unit will enter pause mode.)

⑱ **RANDOM PLAY key**

Press to begin random playback.

⑲ **REPEAT key**

Press this key for repeat playback. Pressing the key once, twice, or three times will change the repeat mode from single track repeat, all tracks repeat, and repeat playback cancellation.

Single track repeat:

The currently-playing track will repeat. The key can be used during normal playback, program playback, random playback.

All tracks repeat:

All tracks on the disc will be repeated.

- If pressed during normal playback mode, all tracks on the disc will be repeatedly played back.
- If pressed during programmed playback, the programmed tracks will be repeatedly played back in the programmed order.
- In the case of random play mode, after all the tracks have been played, random play will start again.

⑳ **PLAY key/indicator (▷)**

Press to begin playback, and to cancel the pause mode.

㉑ **PAUSE key/indicator (⏸)**

Press to temporarily interrupt playback. When pressed again, the pause mode is cancelled and playback resumes.

㉒ **PHONES (headphones) jack**

When you wish to use headphones, insert the plug for the headphones into the headphone jack.

23 PHONES LEVEL control knob

Use to adjust the level of sound when using headphones. Turning the knob to the right increases the sound level.

24 STOP key (■)

Press to stop playback. When pressed, the player goes into stop mode and all operations stop.

NOTE:

The output level of the digital out output (digital data) cannot be controlled. (It will not fade in or fade out.)

Reference:

Fade-in : With no sound, the sound fades in gradually getting louder.

Fade-out : The sound gradually gets softer until there is no sound.

REAR PANEL

Coaxial digital output terminal (DIGITAL OUT)

This terminal allows output of disc audio data and subcode (signals which can be recorded together with the audio signal) as digital signals.

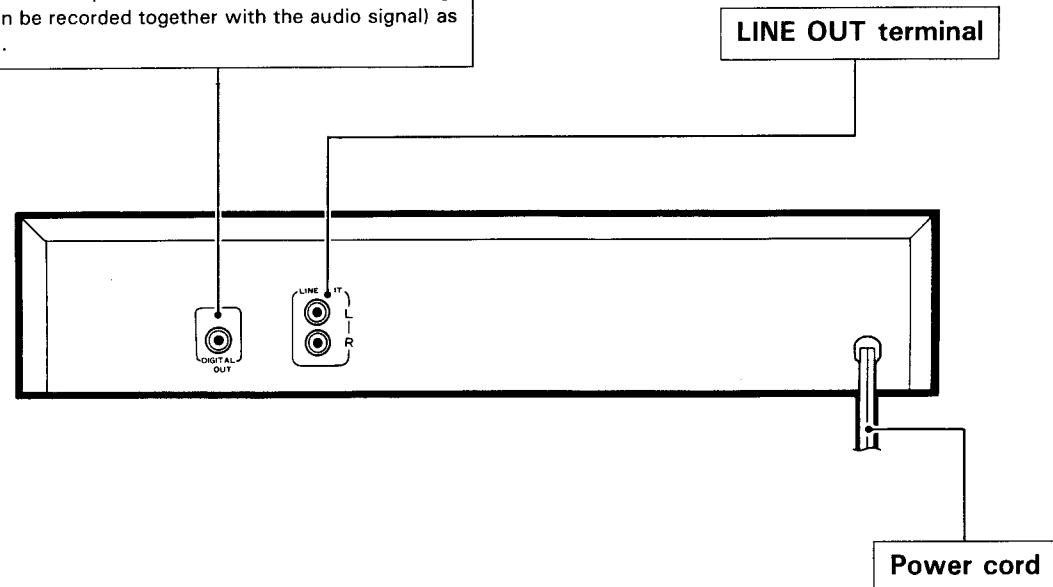

REMOTE CONTROL UNIT

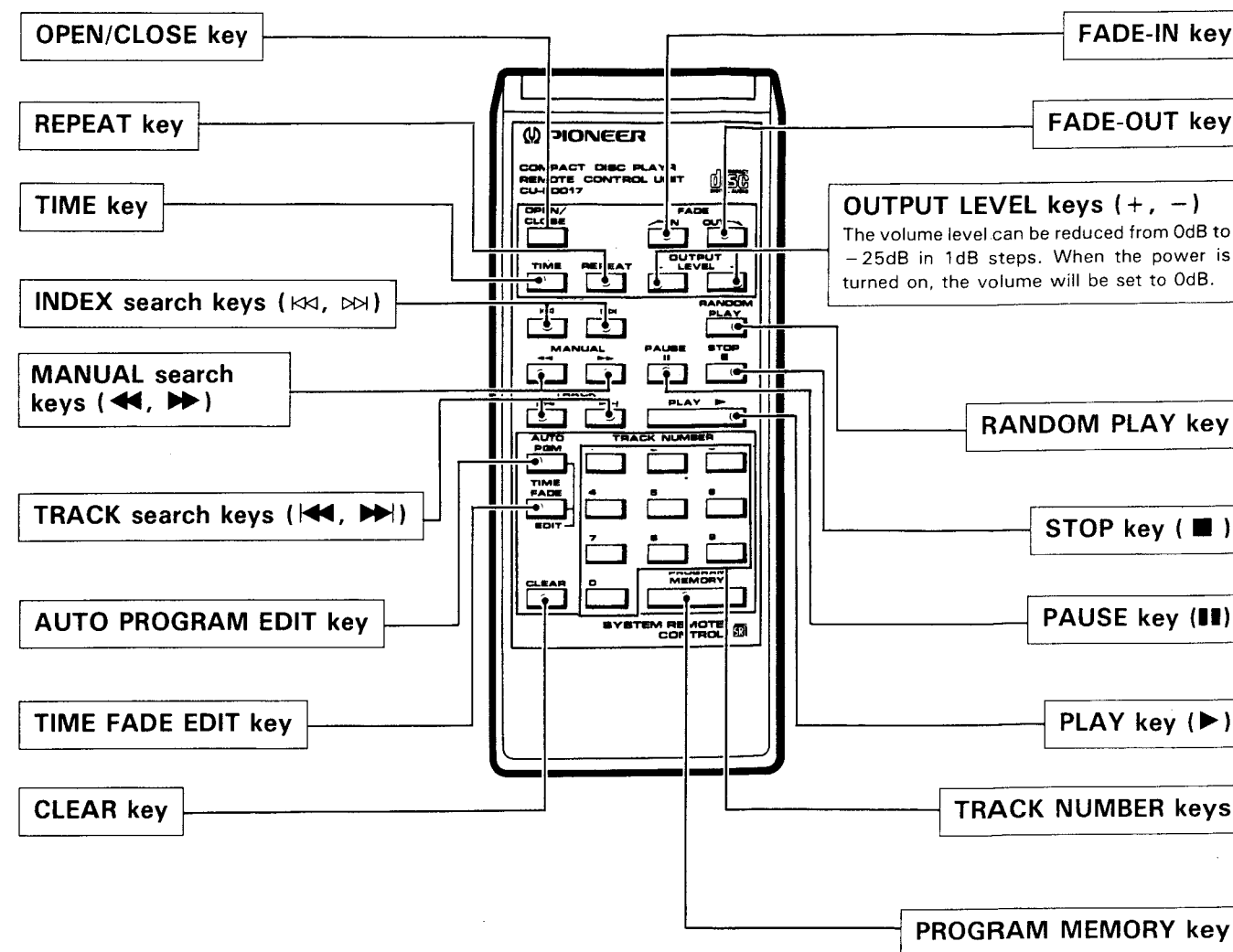

Digital level controller

By using the OUTPUT LEVEL keys [+ , -], the volume level can be controlled in 1dB steps from 0dB to -25dB of the digital circuit processing.

- To increase the volume level: Press the [+ ] LEVEL key. (If the volume level is already set at 0dB, there will be no change.)
- To decrease the volume level: Press the [- ] LEVEL key. (When the key is held down, the volume level will stop at -25dB).

When the volume level is adjusted, it will be displayed on the ATT LEVEL indicator and the ATT indicator.

NOTE:

The headphones can also be adjusted simultaneously. However, the volume level of the digital output from the DIGITAL OUT terminal cannot be adjusted.

# 4. EXPLODED VIEWS AND PARTS LIST

## 4.1 EXTERIOR

A

B

C

D

A

B

C

D

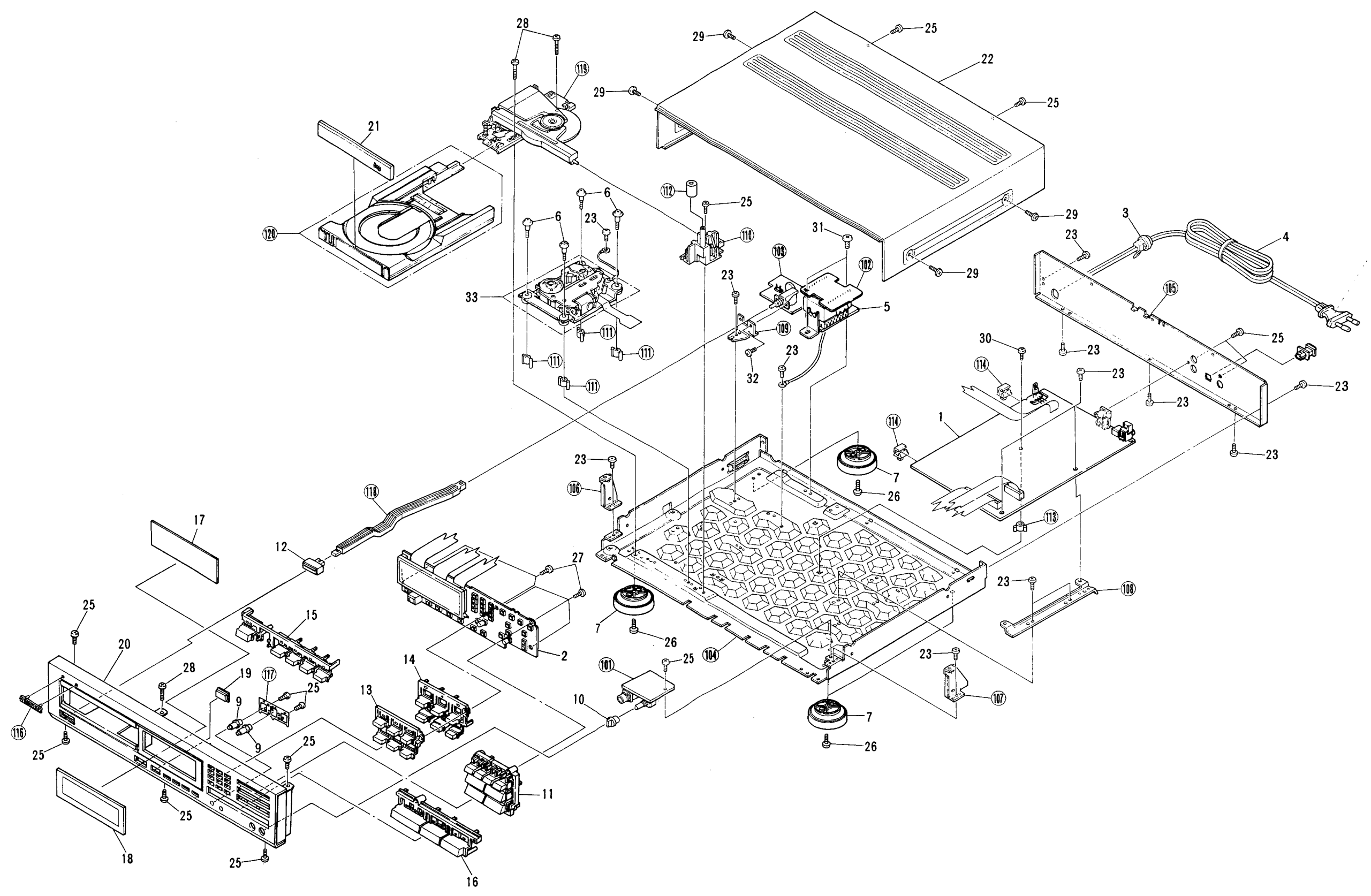



4.2 MECHANISM SECTION

Parts List of Exterior

NOTES :

- Parts without part number cannot be supplied.
- The  $\Delta$  mark found on some component parts indicates the importance of the safety factor of the part. Therefore, when replacing, be sure to use parts of identical designation.
- For your parts Stock Control, the fast moving items are indicated with the marks  $\star\star$  and  $\star$ .  
 $\star\star$  GENERALLY MOVES FASTER THAN  $\star$ .  
 This classification shall be adjusted by each distributor because it depends on model number, temperature, humidity, etc.
- Parts marked by "⊙" are not always kept in stock. Their delivery time may be longer than usual or they may be unavailable.

Mark	No.	Part No.	Description	Mark	No.	Part No.	Description
$\Delta$	⊙	1	PWZ1426			111	Main board assembly
	⊙	2	PWX1037			112	Control board assembly
$\Delta$		3	CM-22B			113	Strain relief
$\Delta$		4	PDG1003			114	AC power cord
$\Delta$	$\star$	5	PTT1063			115	Power transformer
		6	PBA1001			116	Screw
		7	PNW1376			117	Insulator
		8				118	.....
		9	PAA1004			119	Button
		10	PAC1208			120	Knob (PHONES LEVEL)
		11	PAC1251				Button (TRACK)
		12	PAC1252				Button B (POWER)
		13	PAC1253				Button C (SELECT)
		14	PAC1254				Button D (SELECT)
		15	PAC1256				Button C (OPEN/CLOSE)
		16	PAD1035				Play button B assembly
		17	PAM1232				FL filter B
		18	PAM1177				Display window C
		19	PNW1075				Receiving window
		20	PNW1357				Control panel C
		21	PNW1358				Name plate B
		22	PYY1062				Bonnet
		23	BBZ30P060FMC				Screw
		24					.....
		25	BBZ30P080FZK				Screw
		26	BBZ30P120FMC				Screw
		27	BBZ30P160FMC				Screw
		28	BBZ30P230FMC				Screw
		29	FBT40P080FZK				Screw
		30	IBZ30P150FCU				Screw
		31	IBZ40P080FCC				Screw
		32	PMZ30P060FCU				Screw
		33	PYY1063				Servo mechanism assembly
		101					Headphone board assembly
		102					Transformer board assembly
		103					SW board assembly
		104					Under base
		105					Rear base
		106					Angle
		107					Panel angle
		108					P.C. Board angle
		109					SW angle
		110					Slide guide

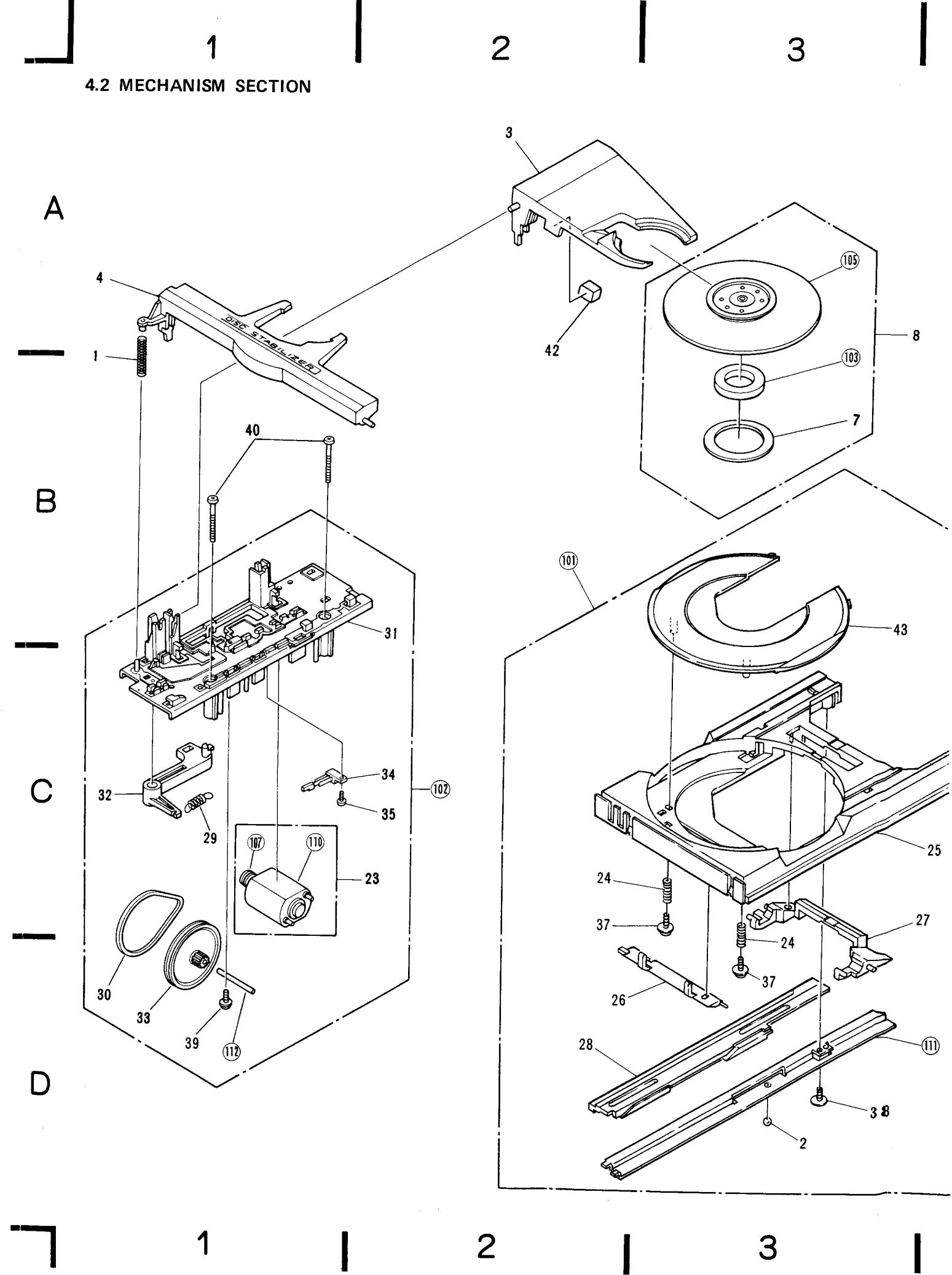

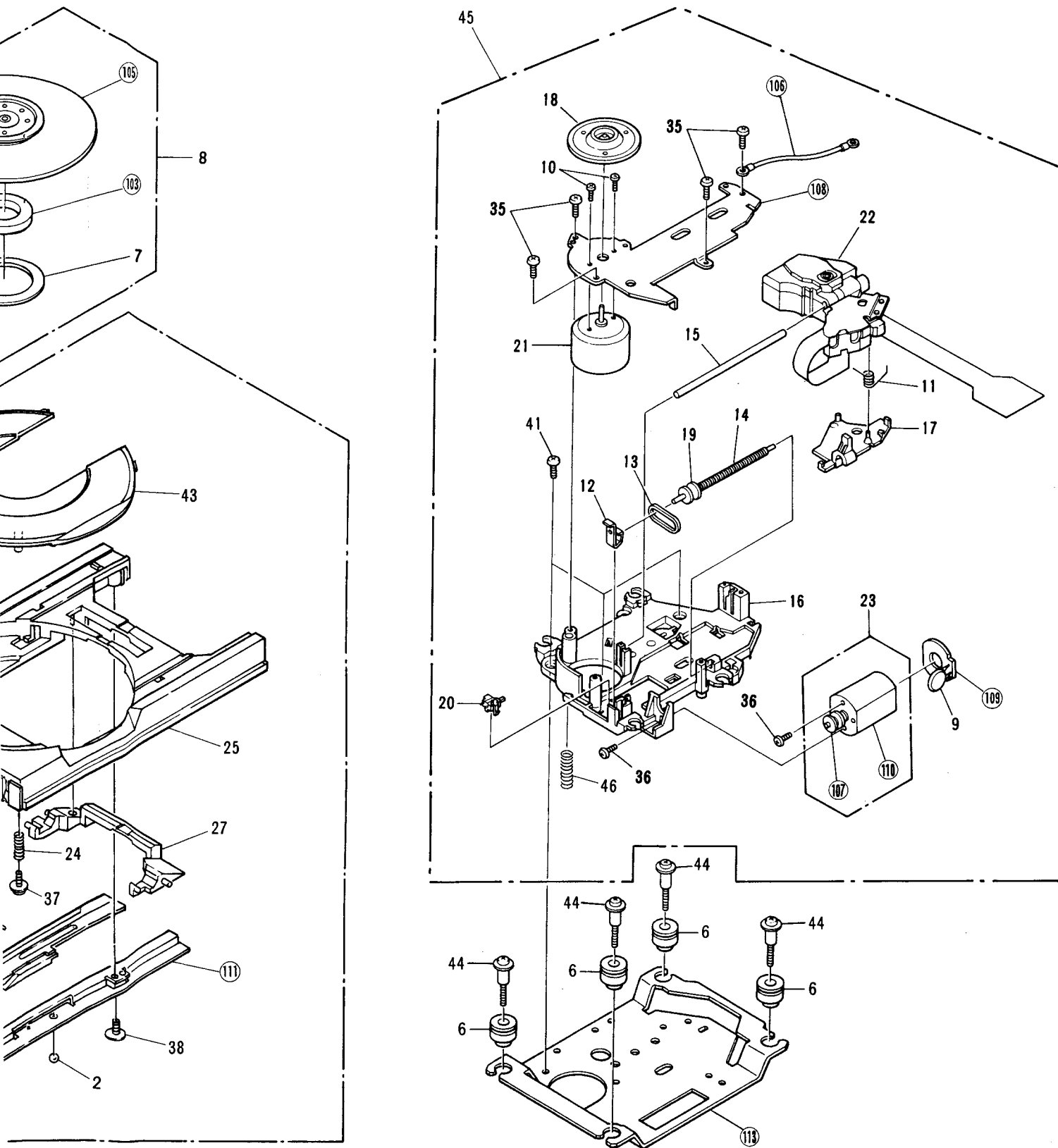

Parts List of Mechanism Section

Mark	No.	Part No.	Description	Mark	No.	Part No.	Description
	1	PBH1013	Spring		31	PNW1069	Loading base
	2	PBP-001	Steel ball φ4		32	PNW1083	Clamp lever
	3	PNW1084	Clamp holder		33	PNW1171	Gear pulley
	4	PNW1085	Clamp retainer	**	34	VSK-015	Leaf switch (S102.OPEN/CLAMP)
	5	PBH1009	Spring		35	BPZ20P080FZK	Screw
	6	PBE1031	Floating rubber		36	PMZ20P030FMC	Screw
	7	PNM1010	Disc cushion		37	PBA1025	Screw
	8	PYY1028	Clamper assembly		38	PPZ30P080FMC	Screw
	9	CGDYX104M25	Semiconductive ceramic capacitor		39	IPZ30P060FMC	Screw
	10	PBA-209	Screw M2 x 3		40	BBZ30P230FMC	Screw
	11	PBH1008	Drive spring		41	BBZ30P080FCC	Screw
	12	PBK1010	Plate spring		42	PEB1095	Stopper rubber
**	13	PEB1072	Belt (CARRIAGE)		43	PNW1329	Disc plate
	14	PLA1003	Drive worm		44	PBA1001	Screw
	15	PLA1004	Guide bar		45	PYY1063	Servo mechanism assembly
	16	PNW1062	Mechanism chassis		46	PBH1009	Earth spring
	17	PNW1063	Carriage plate		101		Tray assembly
	18	PNW1064	Disc table		102		Loading base assembly
	19	PNW1066	Pulley		103		Magnet
**	20	PSH1003	Slide switch (S101. INSIDE)		104		Ballast base
**	21	PXM1001	Spindle motor		105		Clamper
**	22	PWY1003	Pick up assembly		106		Earth lead wire unit
**	23	PYY1025	Motor assembly (CARRIAGE, LOADING)		107		Motor pulley
	24	PBH1045	Plate Spring		108		Base plate
	25	PNW1390	Tray		109		Carriage M board
	26	PNW1330	Plate lever (F)		110		Motor (LOADING, CARRIAGE)
	27	PNW1331	Plate lever (R)		111		Slide base
	28	PNW1332	Rack		112		Gear shaft
	29	PBH1012 PBH1045	Clamp spring		113		Ballast base
**	30	PEB1013	Belt (LOADING)				

A

B

C

D

# 5. SCHEMATIC DIAGRAM

PICK UP ASSEMBLY PWY1003

MAIN BOARD ASSEMBLY PWZ1426

A

B

C

D

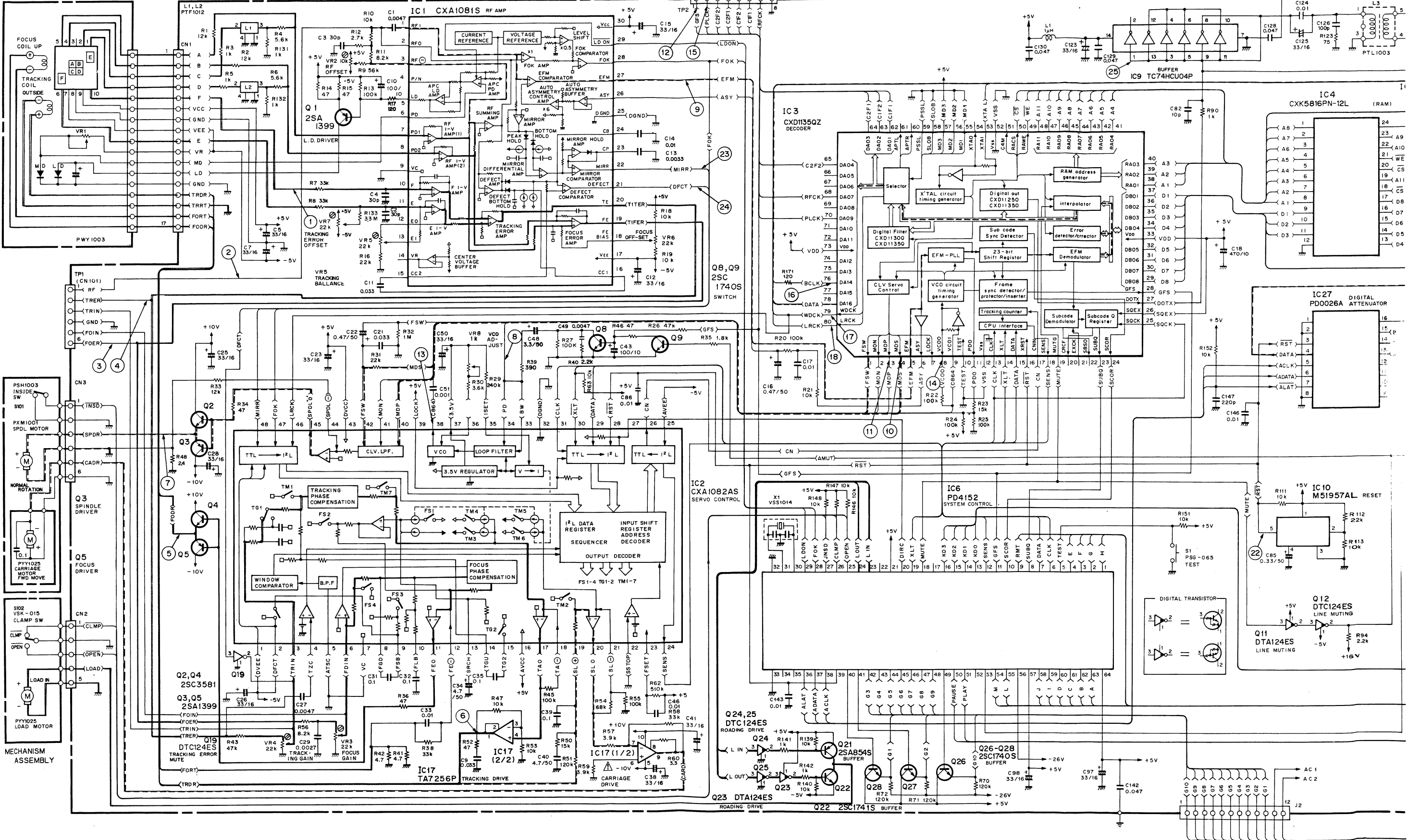

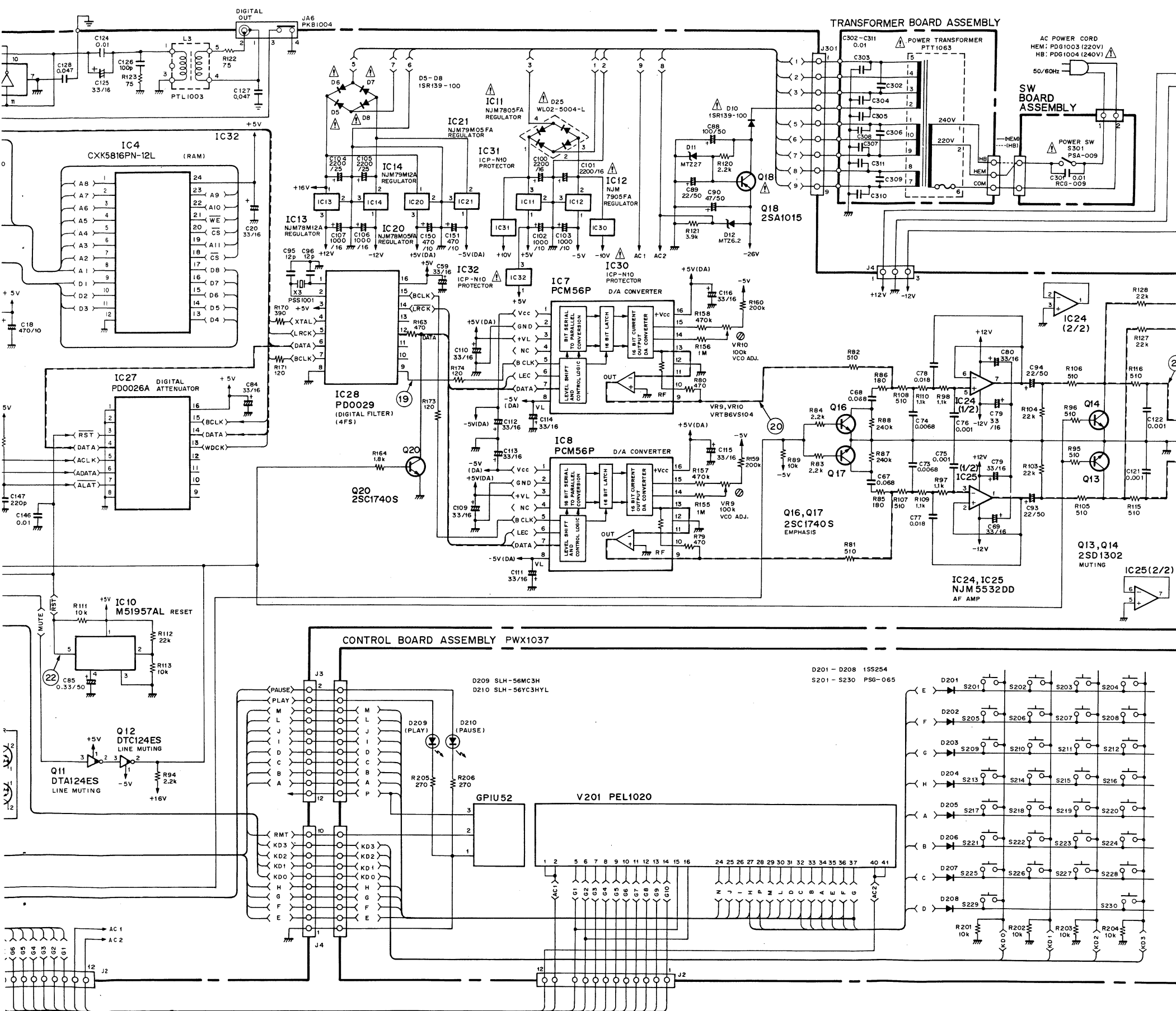

**TRANSFORMER BOARD ASSEMBLY**

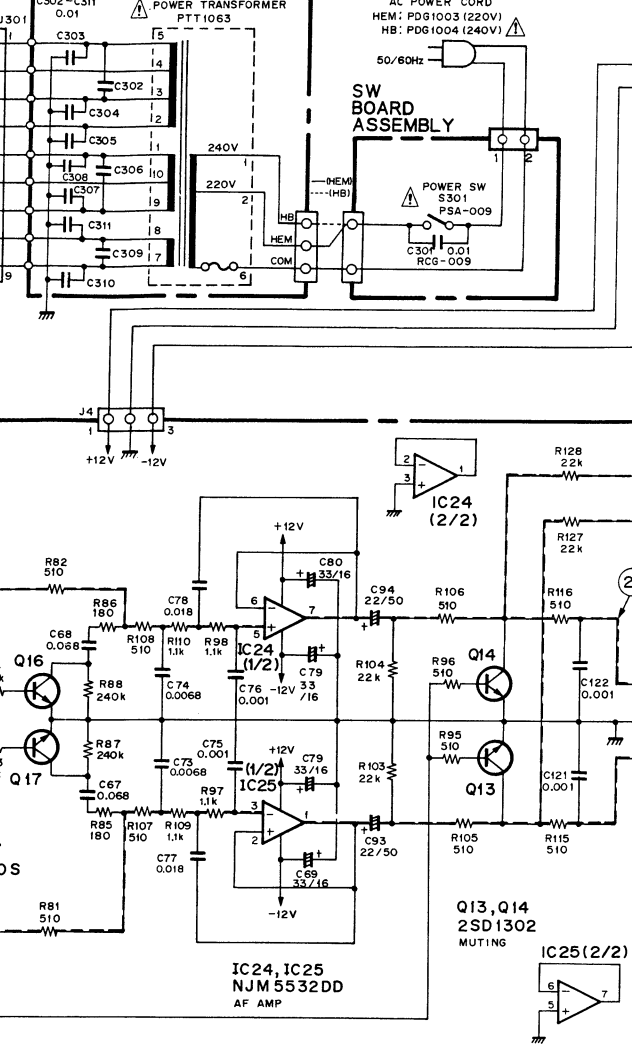

**HEADPHONE BOARD ASSEMBLY**

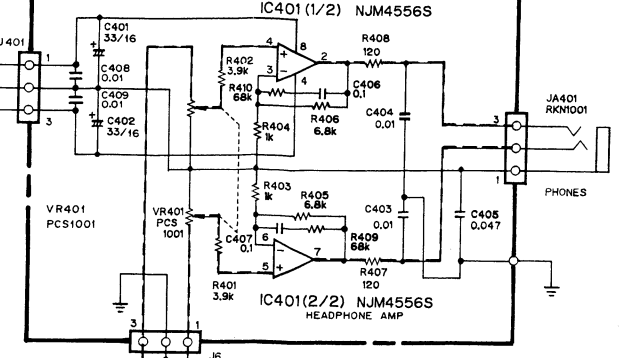

**Line Voltage Selection for HEM and HB types**  
 Line voltage can be changed with following steps  
 1. Disconnect the AC power cord.  
 2. Remove the top cover.  
 3. Change the connection of the TRANSFORMER BOARD ASSEMBLY primary pins.  
 4. Stick the line voltage label on the rear panel.

Parts No.	Description
AAX-193	220V label
AAX-192	240V label

- RESISTORS:**  
Indicated in Ω, 1/4W, 1/6W and 1/8W, ±5% tolerance unless otherwise noted k: kΩ, M: MΩ, (F): ±1%, (G): ±2%, (K): ±10%, (M): ±20% tolerance
  - CAPACITORS:**  
Indicated in capacity (μF)/voltage (V) unless otherwise noted p: pF. Indication without voltage is 50V except electrolytic capacitor.
  - VOLTAGE, CURRENT:**  
⊖: DC voltage (V) at no input signal
  - SWITCHES:**  
The underlined indicates the switch position.  
 MAIN BOARD ASSEMBLY  
 S1: TEST  
 CONTROL BOARD ASSEMBLY  
 S201: OPEN/CLOSE  
 S202: PLAY  
 S203: PROGRAM  
 S204: RANDOM PLAY  
 S205: TRACK SEARCH  
 S206: PAUSE  
 S207: MANUAL SEARCH  
 S208: TIME  
 S209: TRACK SEARCH  
 S210: STOP  
 S211: MANUAL SEARCH  
 S212: REPEAT  
 S213: TRACK NUMBER 1  
 S214: TRACK NUMBER 4  
 S215: TRACK NUMBER 7  
 S216: TRACK NUMBER 0  
 S217: TRACK NUMBER 2  
 S218: TRACK NUMBER 5  
 S219: TRACK NUMBER 8  
 S220: AUTO PROGRAM EDIT  
 S221: TRACK NUMBER 3  
 S222: TRACK NUMBER 6  
 S223: TRACK NUMBER 9  
 S224: AUTO SPACE  
 S225: INDEX SEARCH  
 S226: CLEAR  
 S227: AUTO FADER IN  
 S228: AUTO FADER OUT  
 S229: INDEX SEARCH  
 S230: TIME FADE EDIT  
 SWITCH BOARD ASSEMBLY  
 S301: POWER ON-OFF
- OTHERS:**  
Signal route:  
 ——— FOCUS SERVO LOOP  
 - - - SIGNAL LINE  
 - - - TRACKING SERVO LOOP  
 - - - CARRIAGE SERVO LOOP  
 - - - LOADING MOTOR  
 - - - SPINDLE SERVO LOOP  
 ⊙: Adjusting point.  
 The Δ mark found on some component parts indicates the importance of the safety factor of the part. Therefore, when replacing, be sure to use parts of identical designation.  
 \* marked capacitors and resistors have parts numbers.  
 This is the basic schematic diagram, but the actual circuit may vary due to improvements in design.

FOR SD TYPE

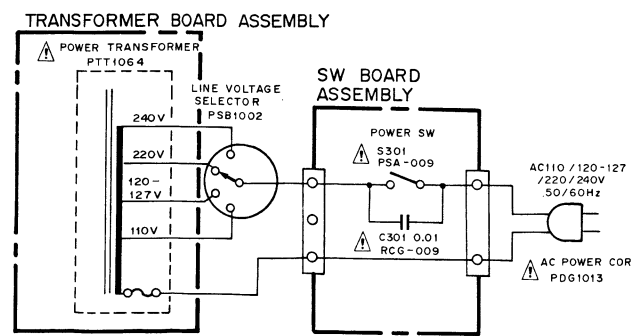

WAVE FORMS

NOTE: The encircled numbers denote measuring points in the circuit and pattern diagrams.

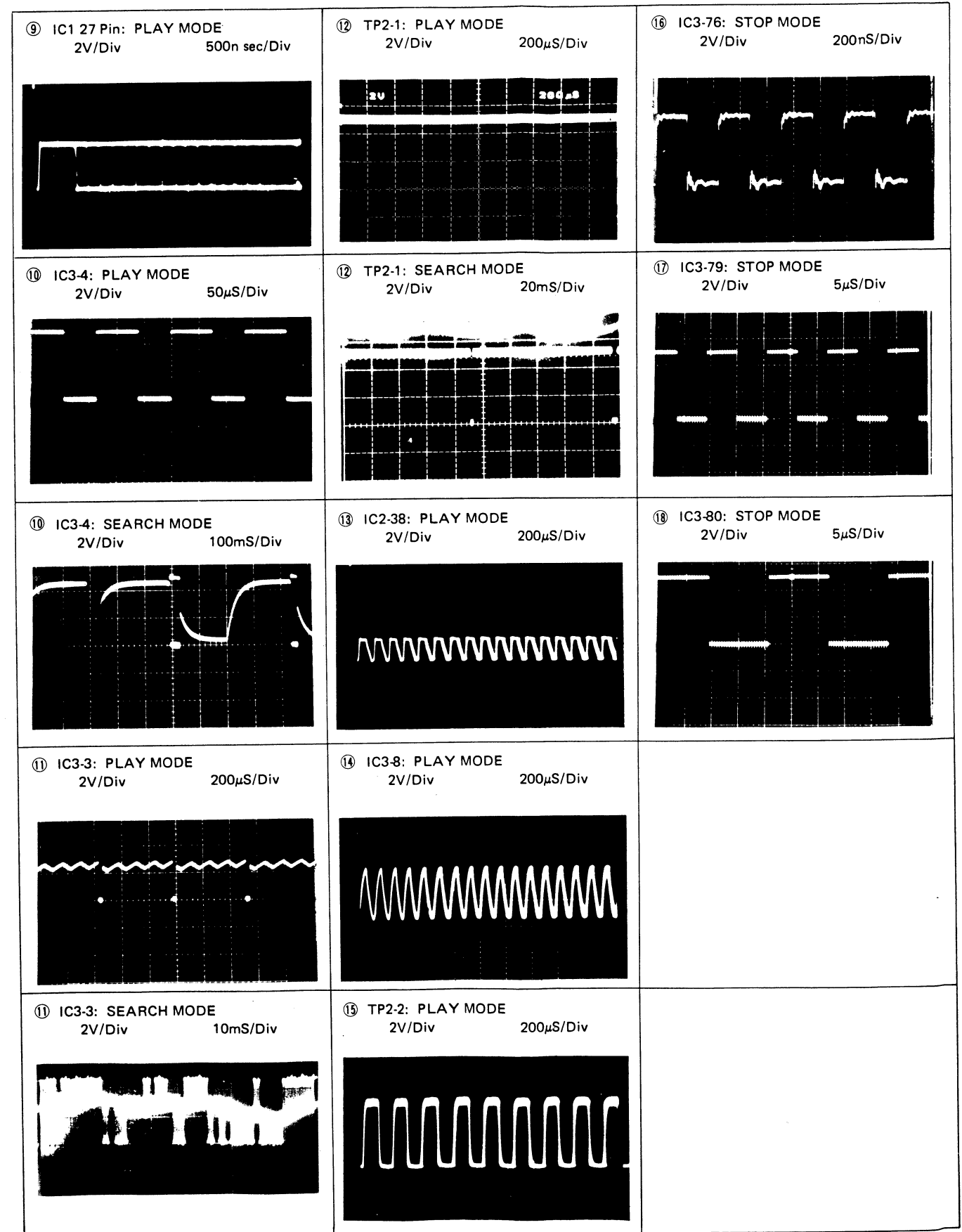
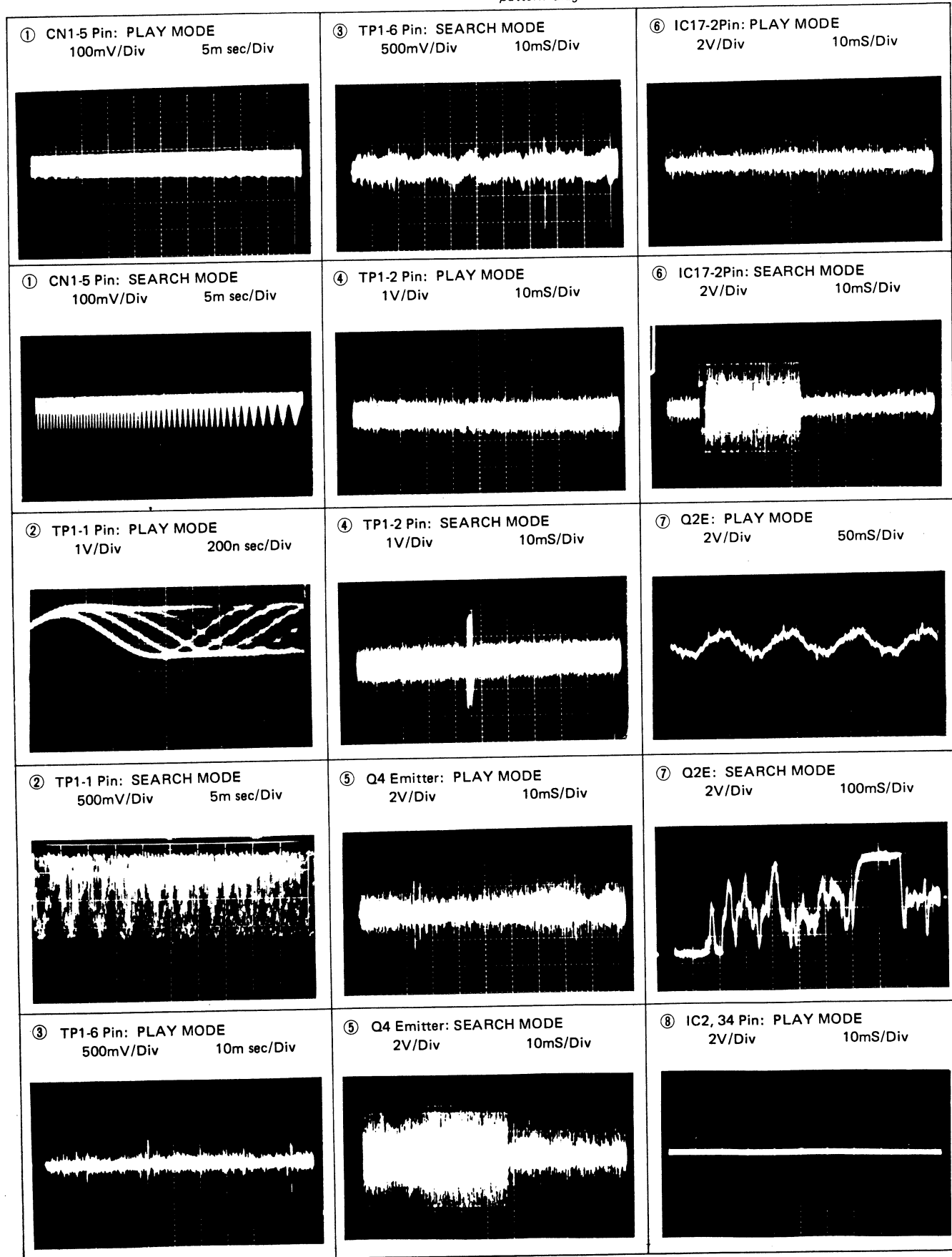

nts in the circuit and

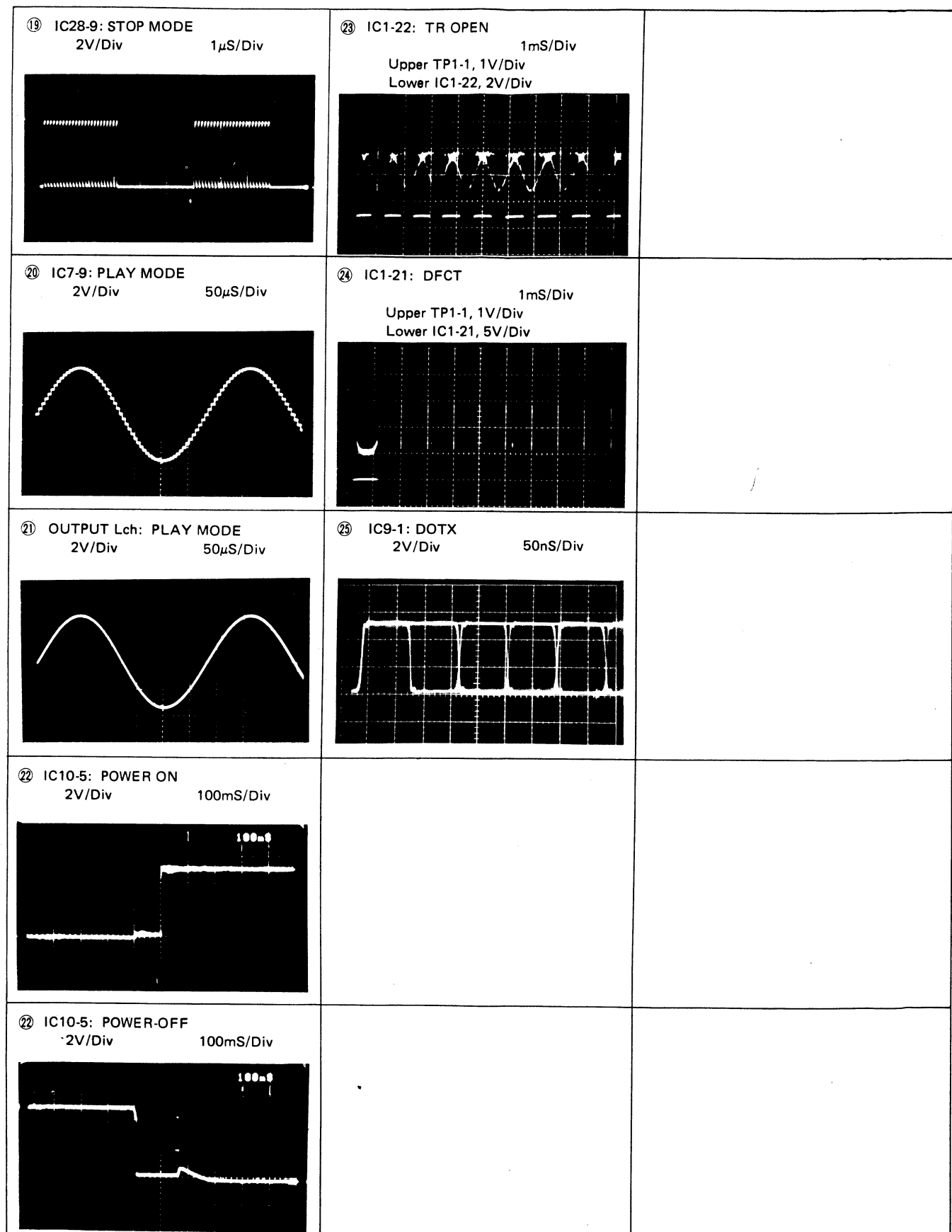
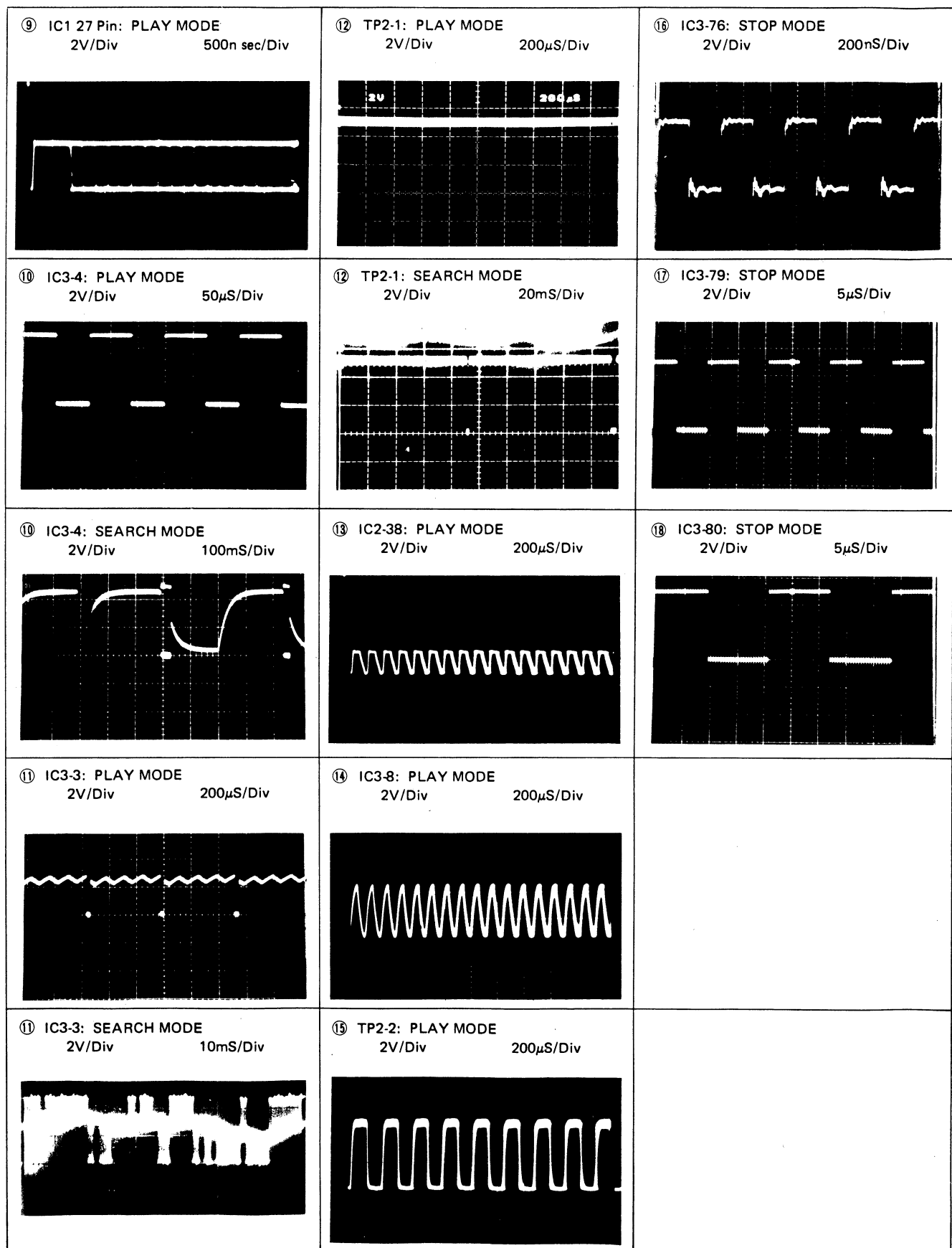
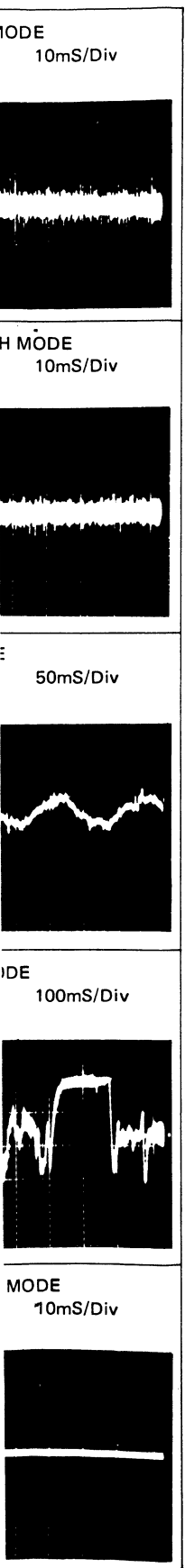

# 6. BLOCK DIAGRAM

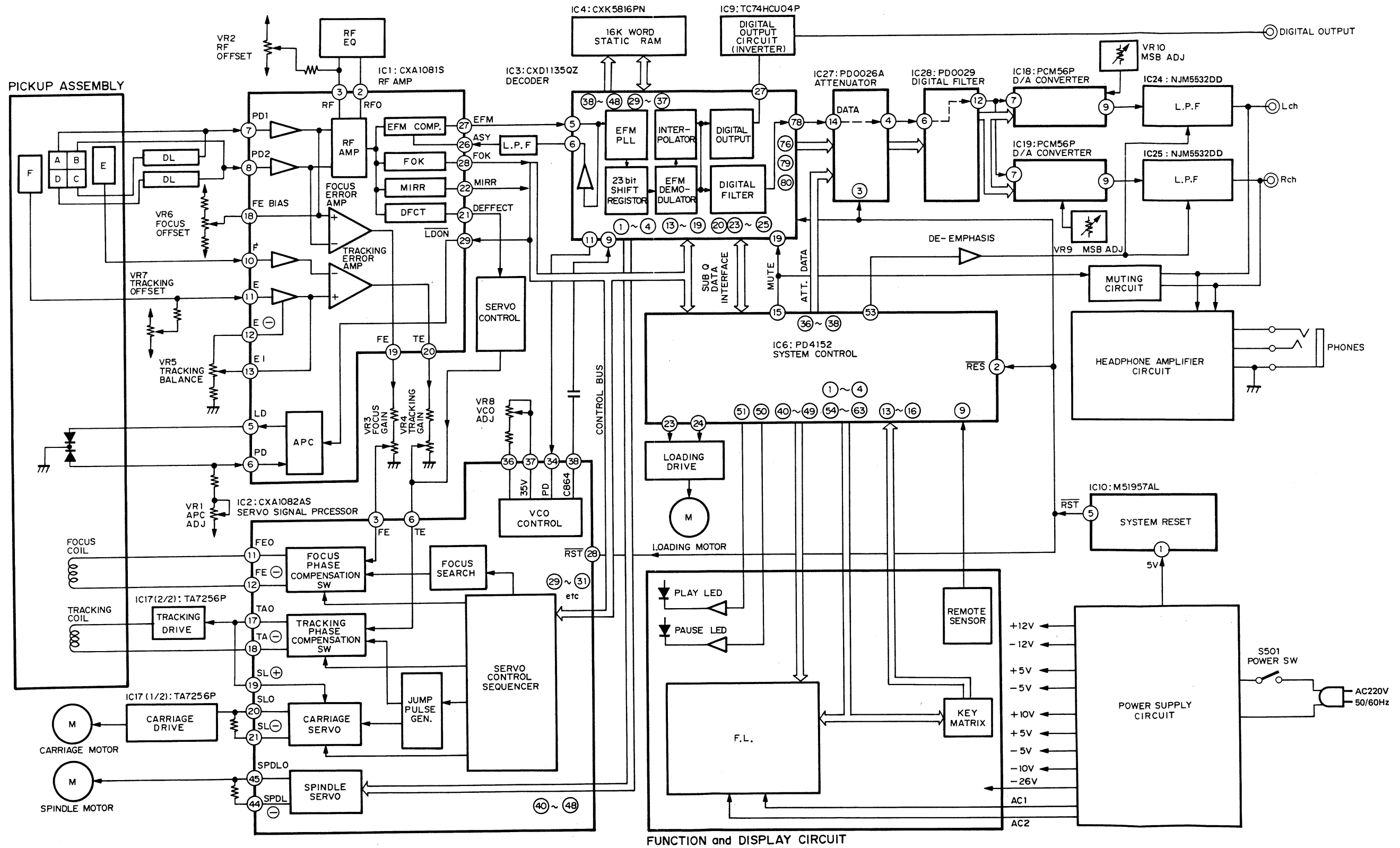

External

CXA1081S

CXD1135QZ

CXK5816PN

ICP-N10

TA7256P



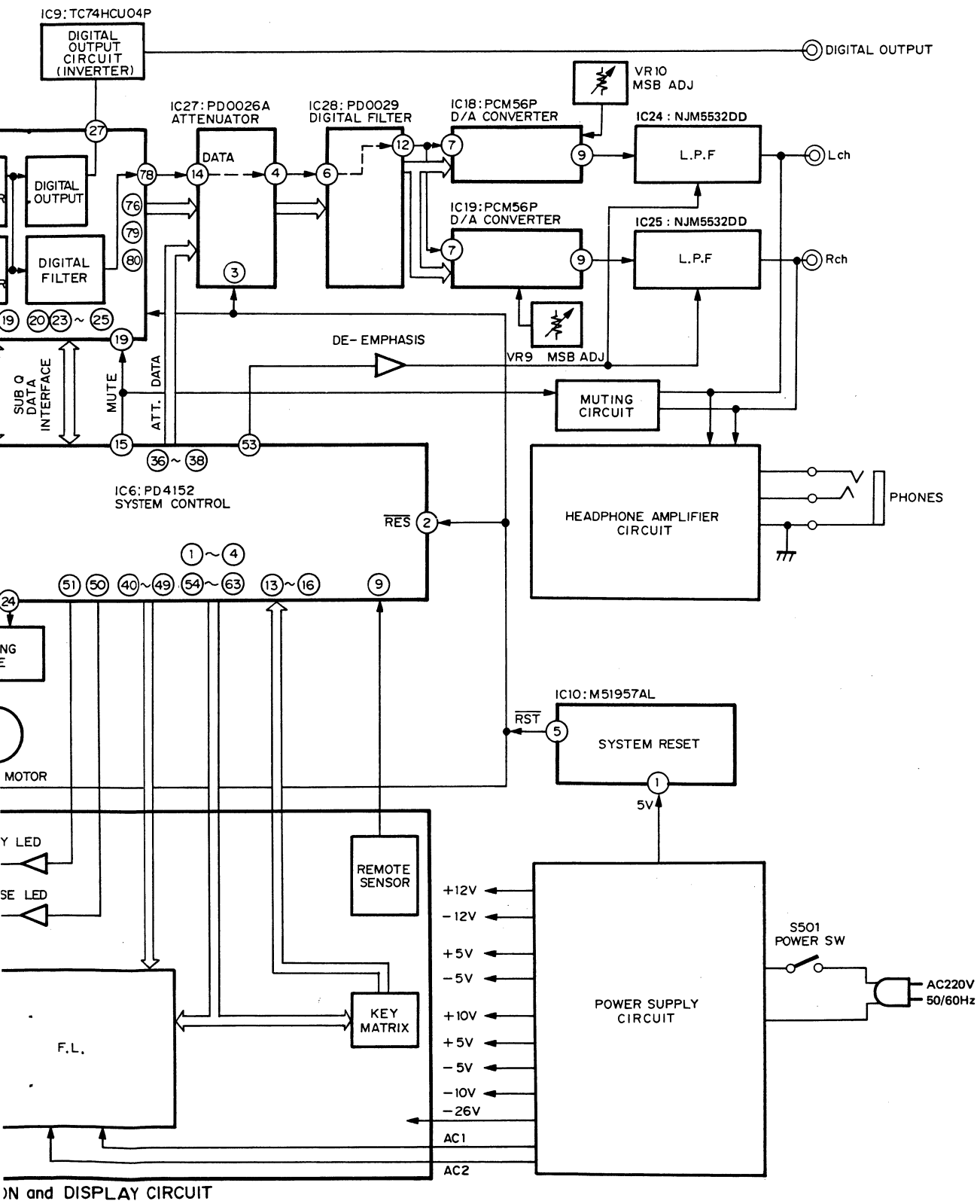

### External Appearance of Transistors and ICs

CXA1081S

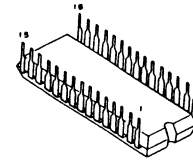

TC74HCU04P

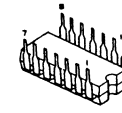

NJM7805FA

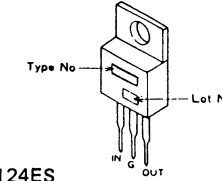

2SD1302

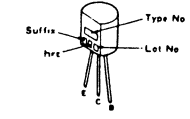

CXD1135QZ

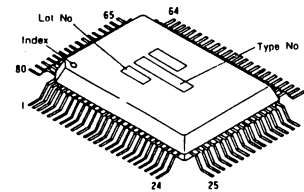

M51957AL

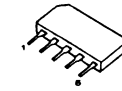

DTA124ES  
DTC124ES



CXA1082AS

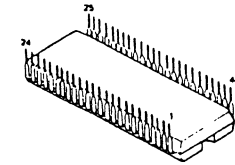

CXK5816PN

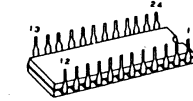

NJM79M12FA  
NJM79M05FA  
NJM7905FA

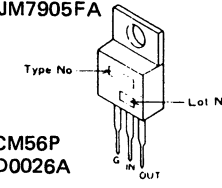

2SA1015

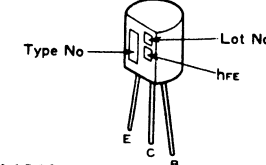

PD0029

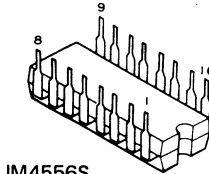

ICP-N10



PCM56P  
PD0026A

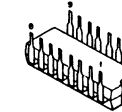

2SA1399  
2SC3581

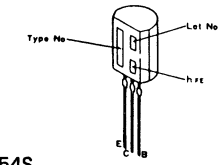

NJM4556S

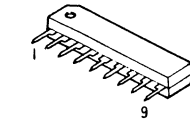

TA7256P

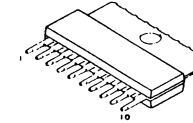

PD4152

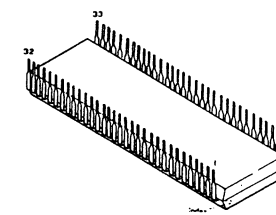

2SA854S  
2SA933S  
2SC1740S  
2SC1741S

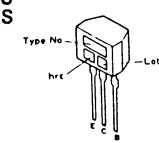

NJM5532DD

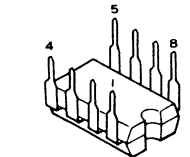

NJM78M12FA

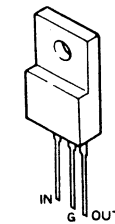



# 7. P.C. BOARDS CONNECTION DIAGRAM

• View from component side

CONTROL BOARD ASSEMBLY PWX1037

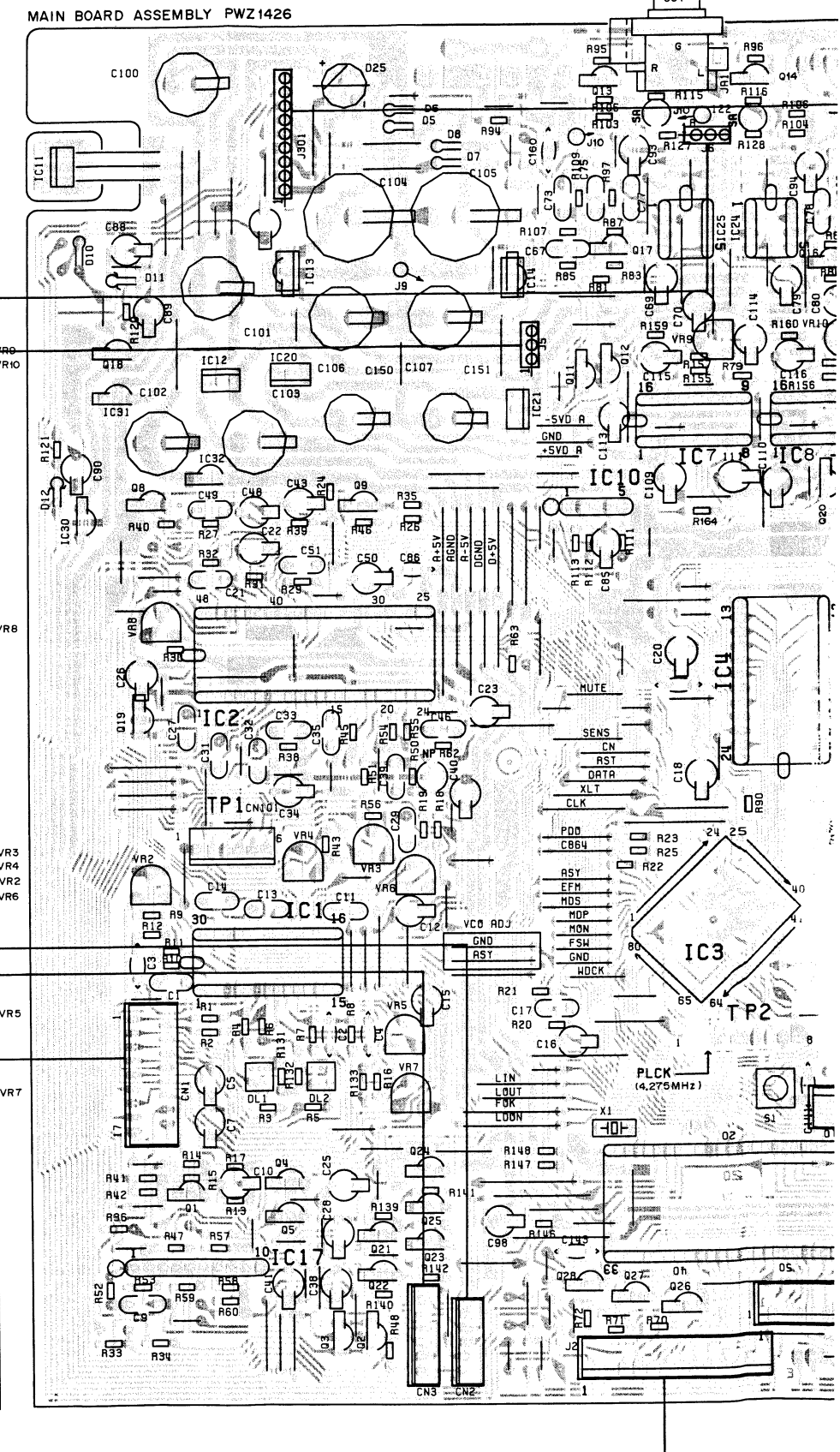
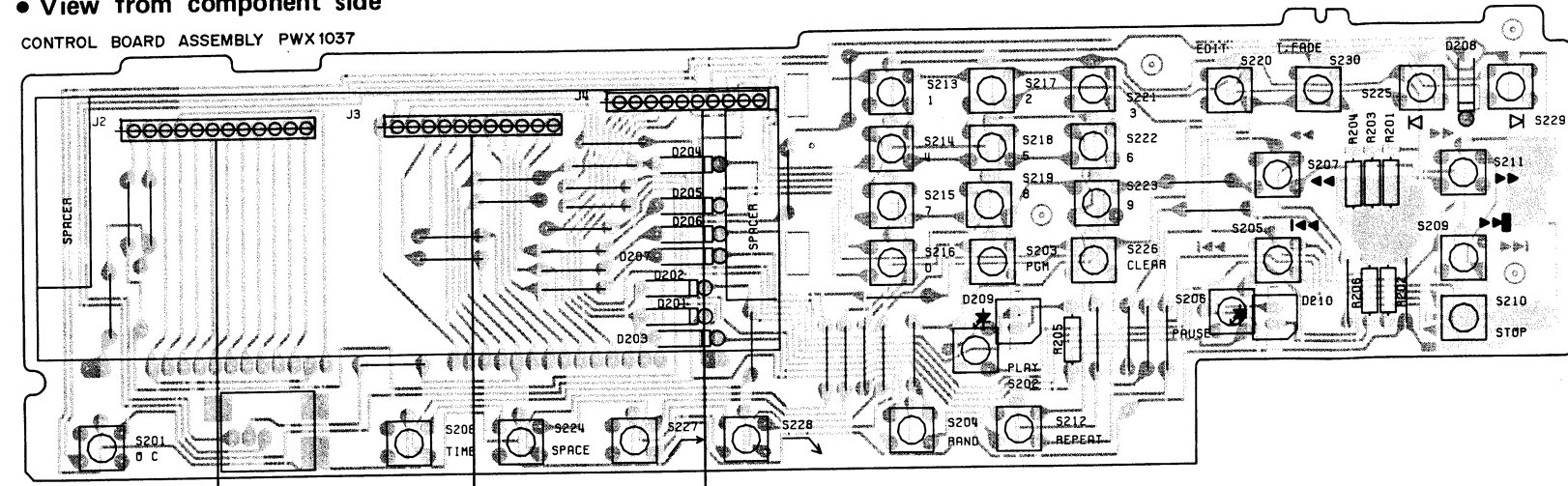

P.C.B. pattern diagram indication	Corresponding part symbol	Part name
		Transistor
		FET
		Diode
		Zener diode
		LED
		Varactor
		Tact switch
		Inductor
		Coil
		Transformer
		Filter
		Ceramic capacitor
		Mylar capacitor
		Styrol capacitor
		Electrolytic capacitor (Non polarized)
		Electrolytic capacitor (Nonleak)
		Electrolytic capacitor (Polarized)
		Electrolytic capacitor (Polarized)
		Power capacitor
		Semi-fixed resistor
		Resistor
		Resonator

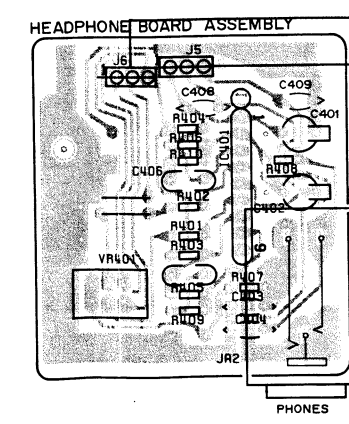
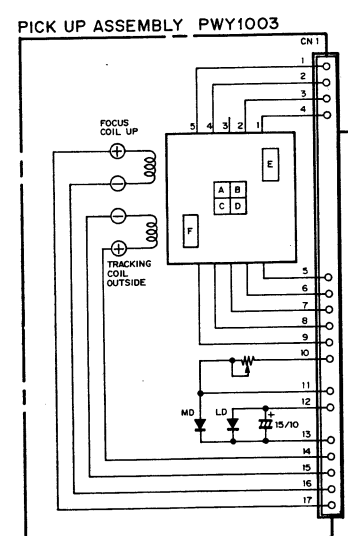
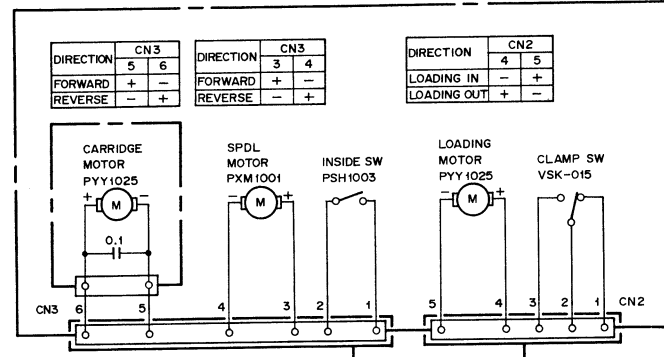

1. The P.C.B. connection diagram is viewed from the parts mounted side.  
 2. The parts which have been mounted on the board can be replaced with those shown with the corresponding wiring symbols listed in the above table.  
 3. The capacitor terminal marked with shows negative terminal.  
 4. The diode marked with shows cathode side.  
 5. The transistor terminal marked with shows emitter.

3 4 5 6 7 8

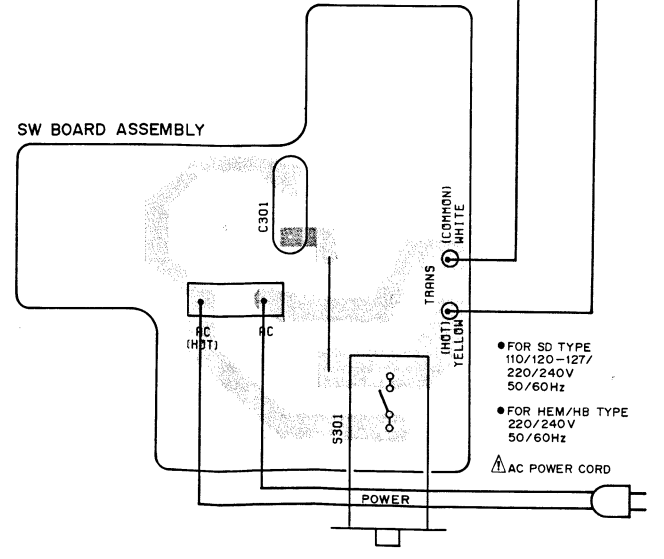
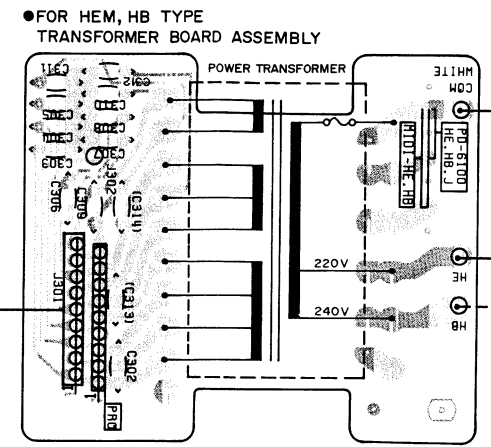
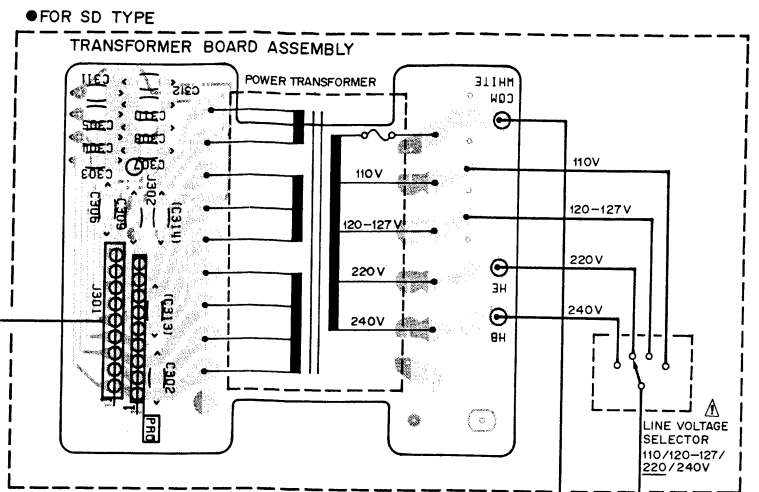
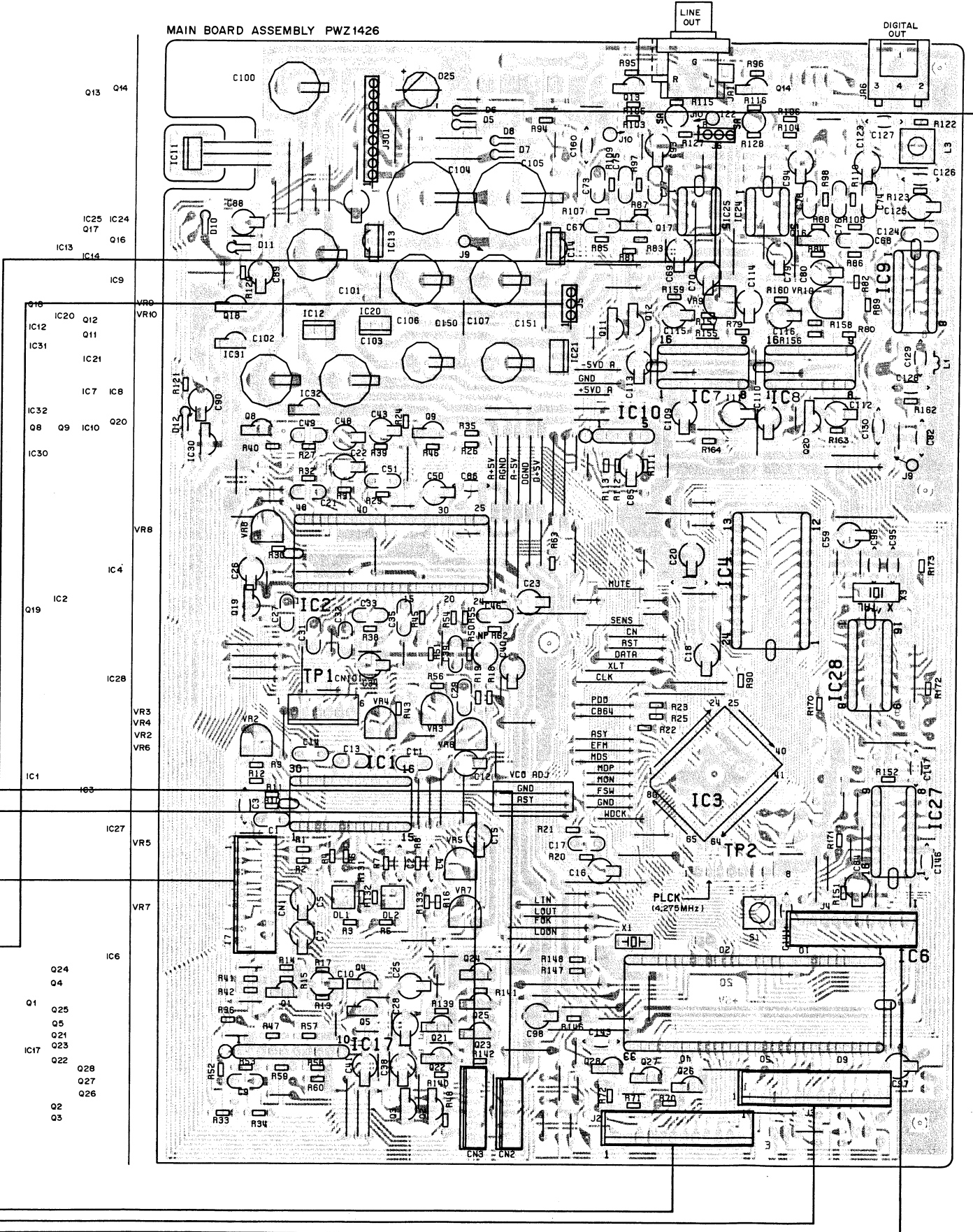
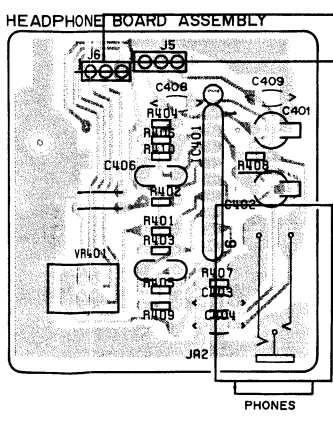
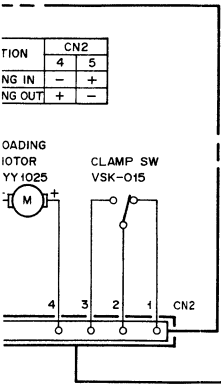
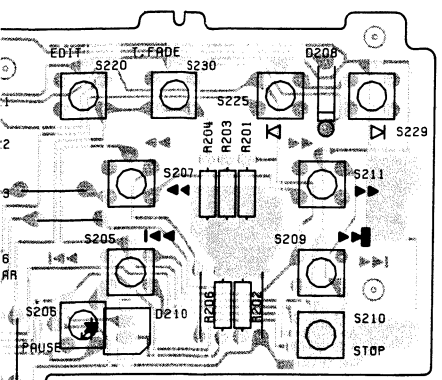

A  
B  
C  
D

4 5 6 7 8 9 27



• View from soldering side

A

B

C

D

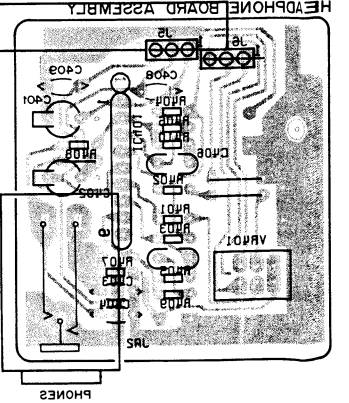
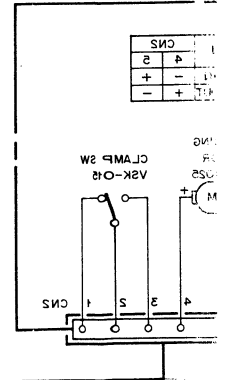
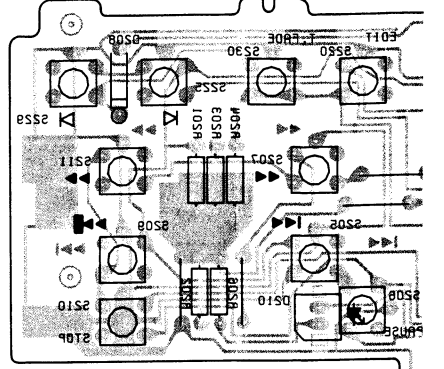
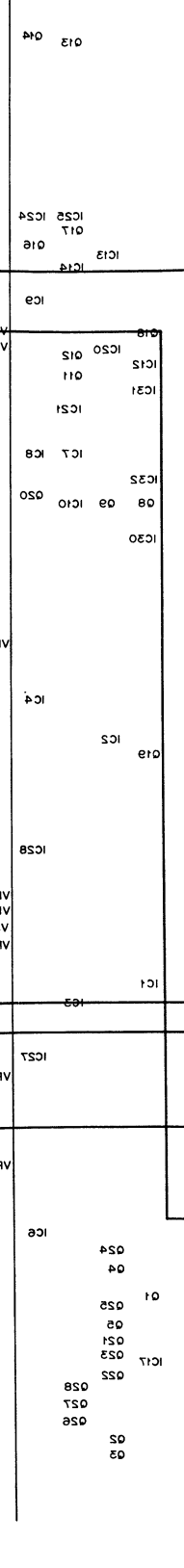
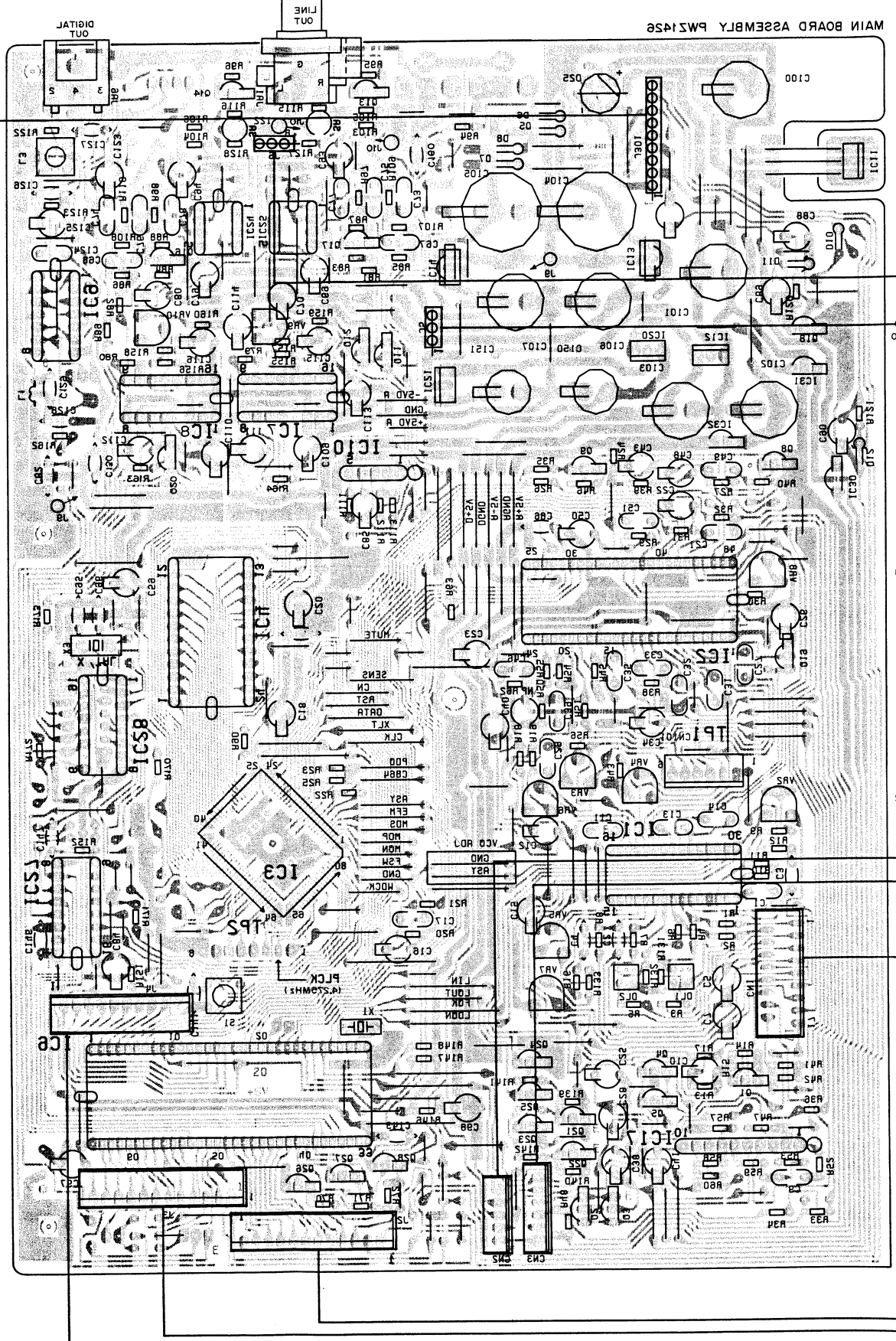
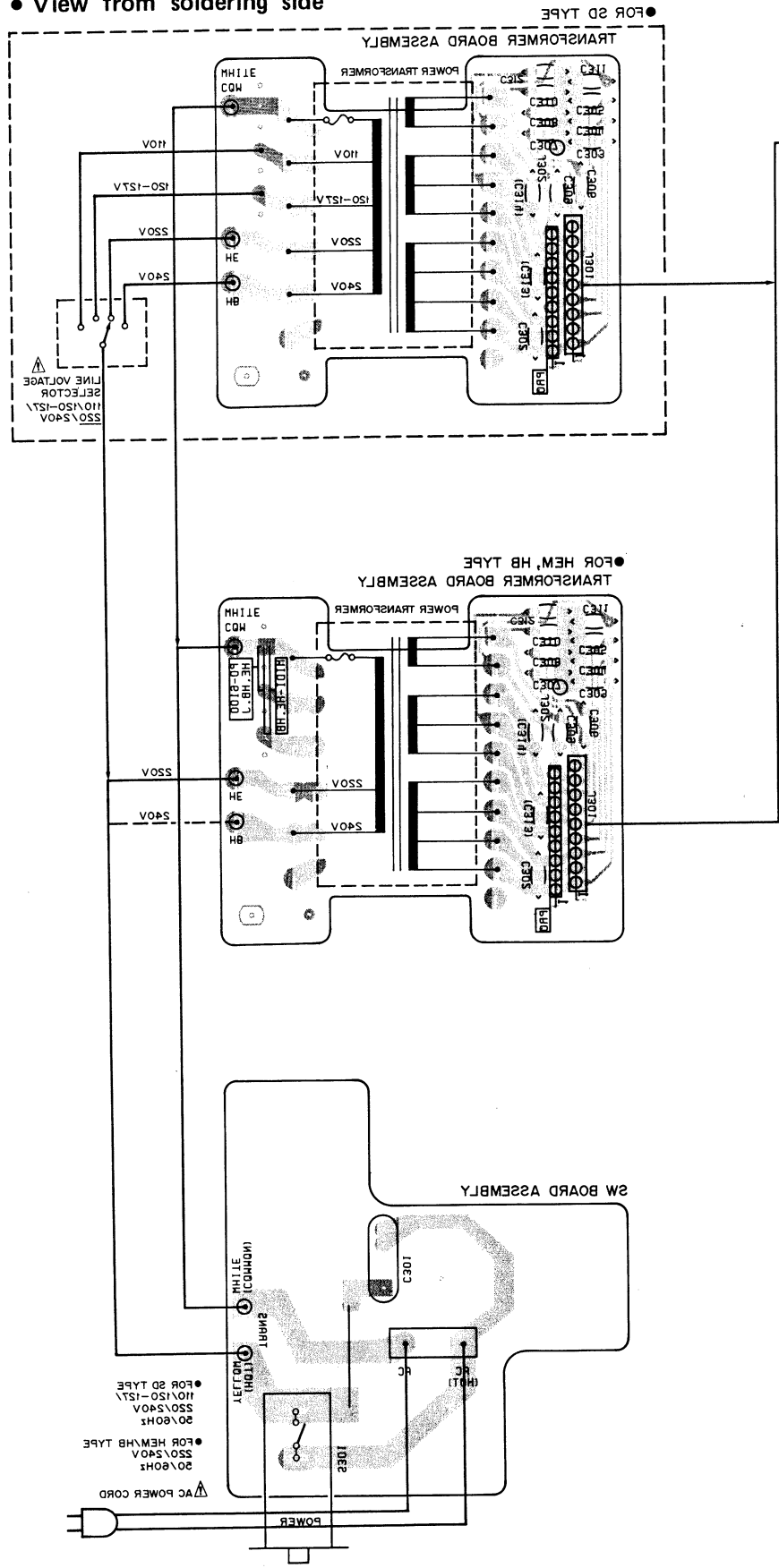

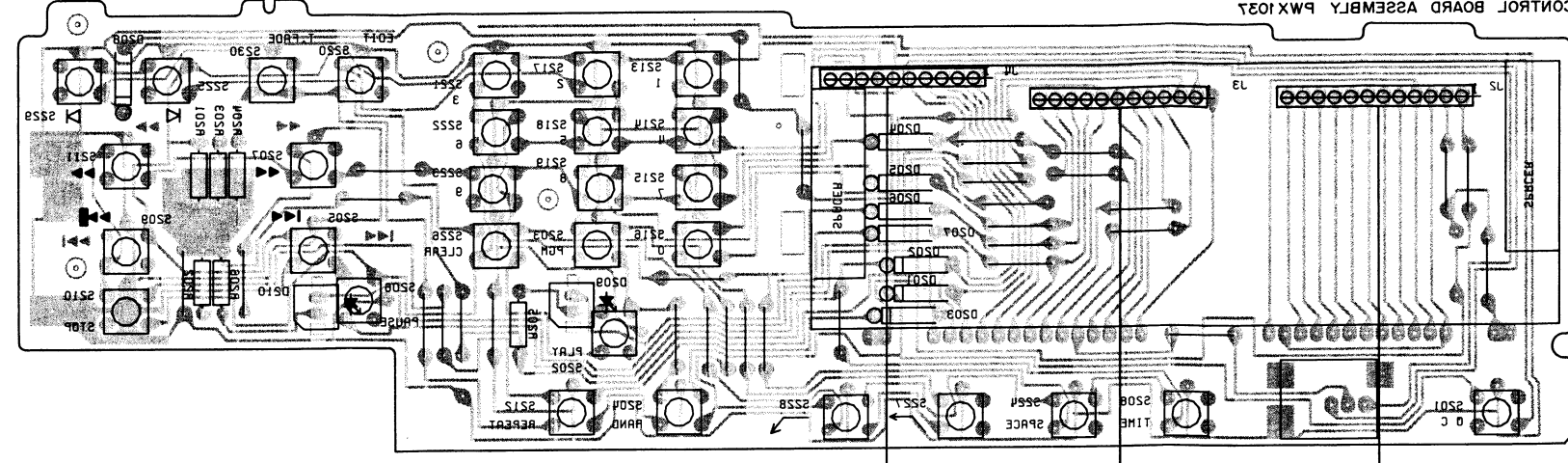
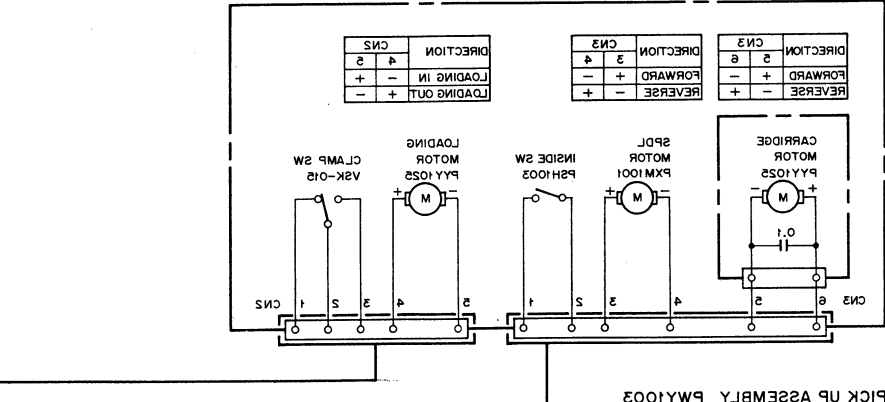
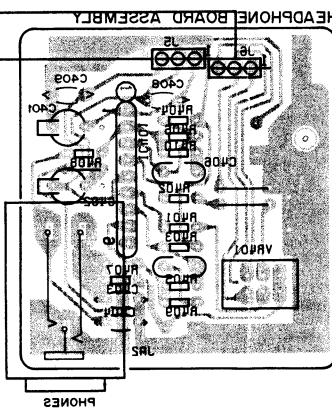
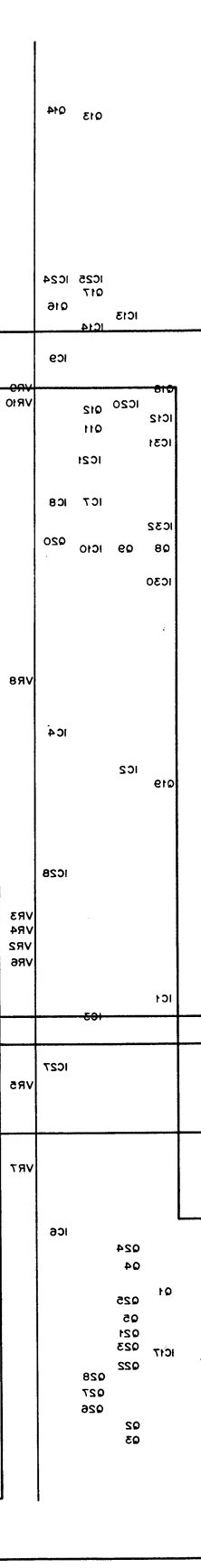
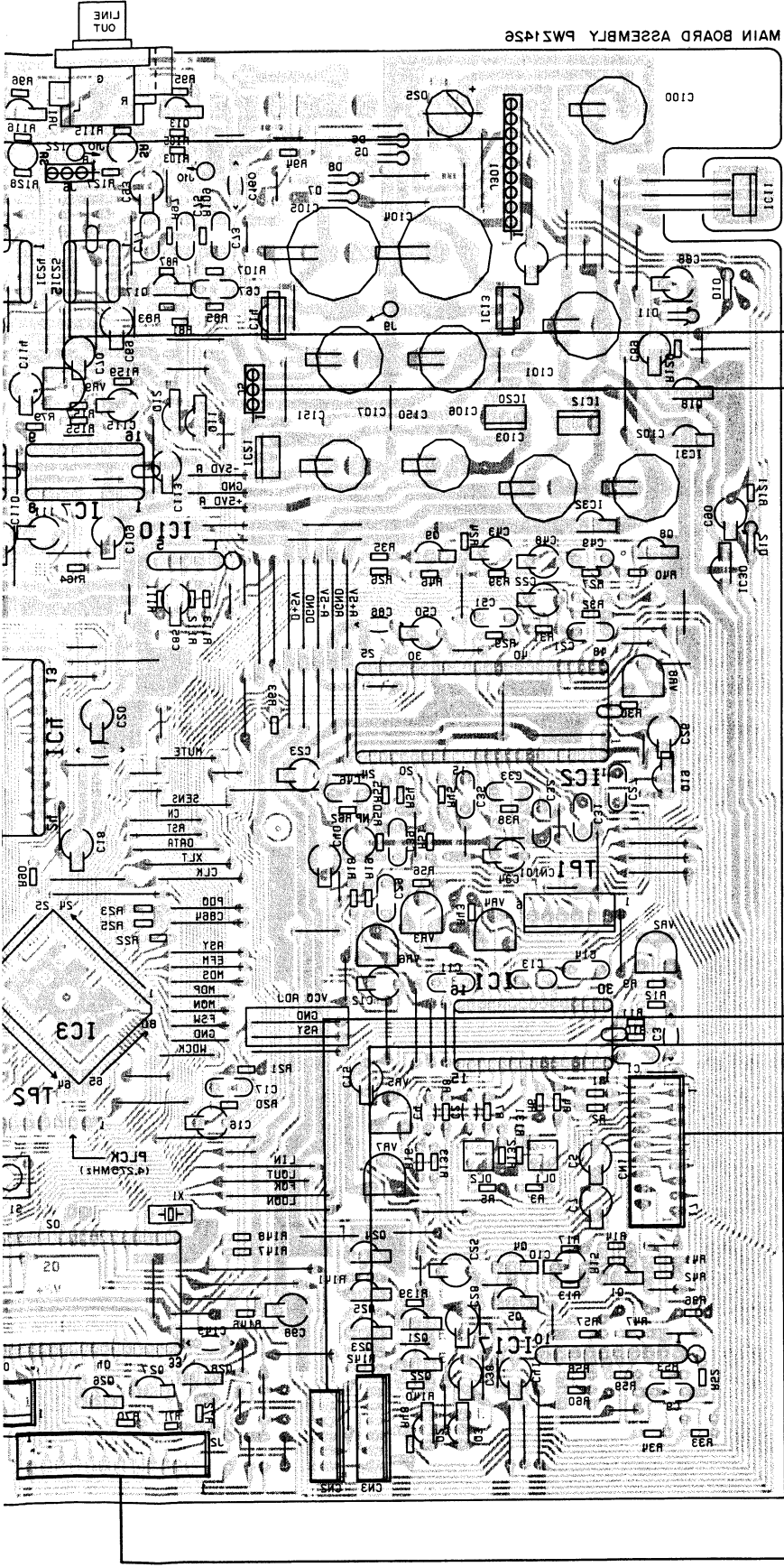

A

B

C

D

1  
2  
3  
4  
5  
6

1  
2  
3  
4  
5  
6

1  
2  
3  
4  
5  
6

1  
2  
3  
4  
5  
6

## 8. PACKING

### Parts list

Mark	No.	Part No.	Description
	1	PDE1002	Connection cord
	2	PRE1052	Operating instructions (English, German, French, Italian)
	3	PRF1007	Operating instructions (Dutch, Spanish, Swedish, Portuguese)
	4	PWW1023	Remote control unit
	5	PHA1059	Protector (L)
	6	PHA1060	Protector (R)
	7	PHC1030	Spacer (in the tray)
	8	PHG1198	Packing case
	9	Z23-007	Sheet
	51		Battery

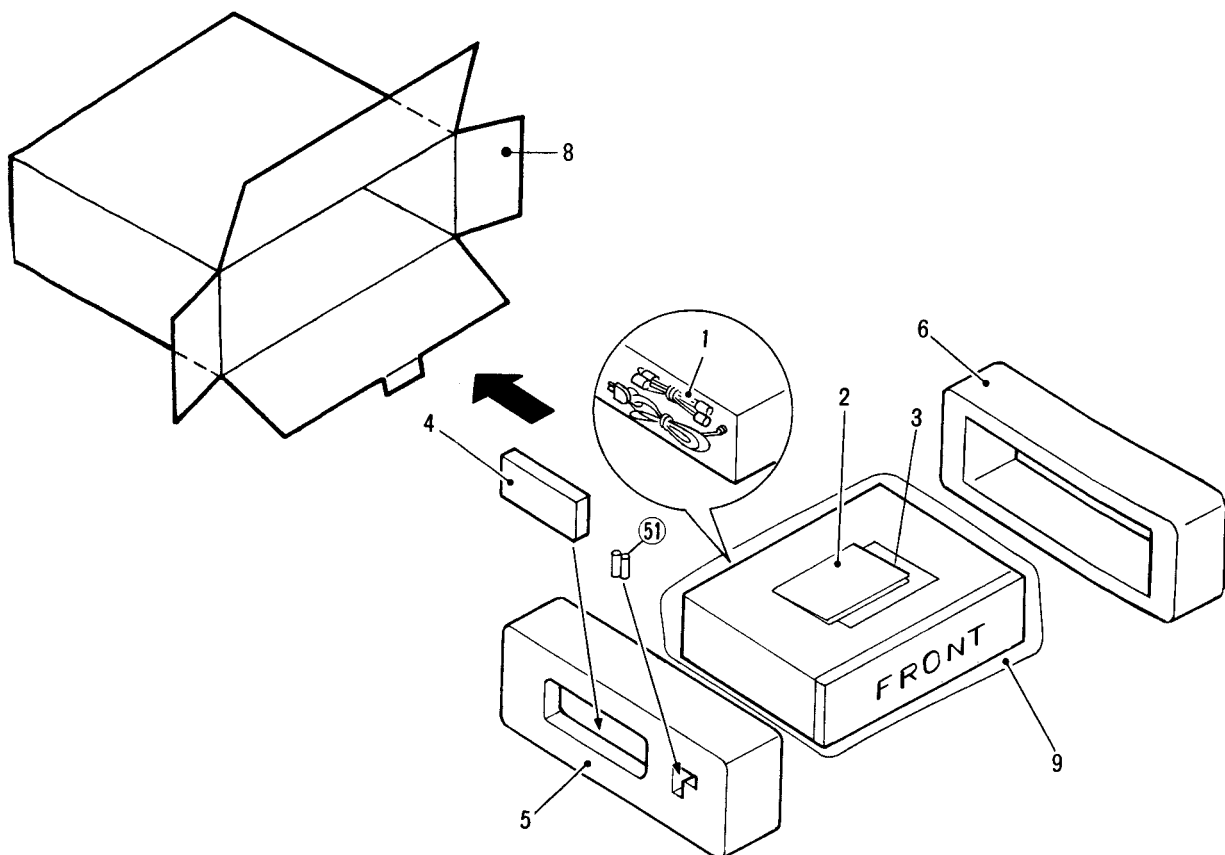

## 9. ELECTRICAL PARTS LIST

### NOTES :

- Parts without part number cannot be supplied.
- Parts marked by "⊙" are not always kept in stock. Their delivery time may be longer than usual or they may be unavailable.
- The Δ mark found on some component parts indicates the importance of the safety factor of the part. Therefore, when replacing, be sure to use parts of identical designation.
- For your parts Stock Control, the fast moving items are indicated with the marks ★★ and ★.

★★ GENERALLY MOVES FASTER THAN ★.

This classification shall be adjusted by each distributor because it depends on model number, temperature, humidity, etc.

- When ordering resistors, first convert resistance values into code form as shown in the following examples.

Ex.1 When there are 2 effective digits (any digit apart from 0), such as 560 ohm and 47k ohm (tolerance is shown by J=5%, and K=10%).

560 Ω	56 × 10 <sup>1</sup>	561	RD1/4PS	561J
47k Ω	47 × 10 <sup>3</sup>	473	RD1/4PS	473J
0.5 Ω	0R5		RN2H	0R5K
1 Ω	010		RS1P	010K

Ex.2 When there are 3 effective digits (such as in high precision metal film resistors).

5.62k Ω	562 × 10 <sup>1</sup>	5621	RN1/4SR	5621F
---------	-----------------------	------	---------	-------

### Miscellaneous Parts

#### P. C. BOARD ASSEMBLIES

Mark	Symbol & Description	Part No.
⊙	Main board assembly	PWZ1426
⊙	Control board assembly	PWX1037
	Headphone board assembly	
Δ	Transformer board assembly	
Δ	SW board assembly	

Mark	Symbol & Description	Part No.
Δ★★	IC11	NJM7805FA
★★	IC21	NJM79M05FA
★★	IC14	NJM79M12FA
Δ★★	IC12	NJM7905FA
★★	IC7, IC8	PCM56P
★★	IC27	PD0026A
★★	IC28	PD0029
★★	IC6	PD4152
Δ★★	IC17	TA7256P
★★	IC9	TC74HCU04P

#### OTHERS

Mark	Symbol & Description	Part No.
Δ	Straine relief	CM-22B
Δ	AC power cord	PDG1003
Δ ★	Power transformer	PTT1063
★★	S101 Slide switch (INSIDE)	PSH1003
★★	S102 Leaf switch (OPEN/CLAMP)	VSK-015
★★	Spindle motor	PXM1001
★★	Motor assembly (CARRIAGE, LOADING)	PYY1025
	Pick up assembly	PWY1003

★★	Q11, Q23	DTA124ES
★★	Q12, Q19, Q24, Q25	DTC124ES
Δ★★	Q18	2SA1015
★★	Q1, Q3, Q5	2SA1399
★★	Q21	2SA854S
★★	Q8, Q9, Q16, Q17, Q20, Q26-Q28	2SC1740S
★★	Q22	2SC1741S
★★	Q2, Q4	2SC3581
★★	Q13, Q14	2SD1302
★	D11	MTZ27B (MTZ27C)
★	D12	MTZ6.2B (MTZ6.2C)
Δ ★	D25	WL02-5004-L
Δ ★	D5-D8, D10	1SR139-100

#### ⊙ Main Board Assembly (BWZ1426)

#### SEMICONDUCTORS

Mark	Symbol & Description	Part No.
★★	IC1	CXA1081S
★★	IC2	CXA1082AS
★★	IC3	CXD1135QZ
★★	IC4	CXK5816PN-12L (CXK5816PN-15L) (LH5116-15)
Δ★★	IC30-IC32	ICP-N10
★★	IC10	M51957AL
★★	IC24, IC25	NJM5532DD
★★	IC20	NJM78M05FA
★★	IC13	NJM78M12FA

#### SWITCH

Mark	Symbol & Description	Part No.
★★	S1 Tact switch (TEST)	PSG-065

**CAPACITORS**

Mark	Symbol & Description	Part No.
	C95, C96	CCCCH120J50
	C82,	CCCCH100D50
	C2-C4	CCCCH300J50
	C126	CCCCL101J50
	C40	CEANP4R7M25
	C85	CEASR33M50
	C147	CCCCL221J50
	C16, C22	CEASR47M50
	C34	CEAS4R7M50
	C10, C43	CEAS101M10
	C88	CEAS101M50
	C102, C103	CEAS102M10
	C106, C107	CEAS102M16
	C89, C93, C94	CEAS220M50
	C100, C101	CEAS222M16
	C104, C105	CEAS222M25
	C48	CEAS3R3M50
	C5, C7, C12, C15, C20, C23,	CEAS330M16
	C25, C26, C28, C38, C41, C50,	
	C59, C69, C70, C79, C80, C84,	
	C97, C98, C109-C116, C123,	
	C125	
	C90	CEAS470M50
	C150, C151, C18	CEAS471M10
	C86, C141, C143, C146	CKCYF103Z50
	C33, C51, C75, C76	CQMA102J50
	C14, C17, C46, C124	CQMA103K50
	C127-C130, C142	CKCYF473Z50
	C31, C32, C35, C39	CQMA104K50
	C29	CQMA272J50
	C13	CQMA332J50
	C9, C11, C21	CQMA333K50
	C1, C27, C49	CQMA472J50
	C77, C78	CQMA183J50
	C67, C68	CQMA683J50
	C121, C122	CQSA102J50
	C73, C74	CQMA682J50

**RESISTORS**

Mark	Symbol & Description	Part No.
★	VR2 Semi-fixed (10k)	VRTB6VS103
★	VR3-VR7 Semi-fixed (22k)	VRTB6VS223
★	VR8 Semi-fixed (1k)	VRTS6VS102
	R30 Metal thin film	RN 1/8 PQ3601F
	VR9, VR10 Semi-fixed (100k)	VRTB6VS104
	Other resistors	RD 1/8 PM □ □ □ J

**OTHERS**

Mark	Symbol & Description	Part No.
	JA6 1P Pinjack (DIGITAL OUT)	PKB1004
	JA1 2P Pinjack (LINE OUT)	PKB1009
★	X3 Crystal resonator	PSS1001
	DL1, DL2 Delay line	PTF1012
	L3 Pulse transformer	PTL1003
	L1 Inductor	LRA010k
★	X1 Ceramic resonator	VSS1014

**Control Board Assembly (PWX1037)**

**SEMICONDUCTORS**

Mark	Symbol & Description	Part No.
★	D209	SLH-56MC3H
★	D210	SLH-56YC3HYL
★	D201-D208	1SS254

**SWITCHES**

Mark	Symbol & Description	Part No.
★★	S201-S230 Tact switch (OPEN/CLOSE, TIME, AUTO SPACE, AUTO FADER IN, AUTO FADER OUT, RANDOM PLAY REPEAT, PROGRAM, CLEAR, TRUCK NUMBER, AUTO PROGRAM EDIT, TIME FADE EDIT, INDEX SEARCH, MANUAL SEARCH, TRACK SEARCH, PLAY, PAUSE, STOP)	PSG-065

**RESISTORS**

Mark	Symbol & Description	Part No.
	All resistors	RD 1/4 PM □ □ □ J

**OTHERS**

Mark	Symbol & Description	Part No.
★	V201 Fluorescent tube Remote control sensor unit	PEL1020 GPU52

**Headphone Board Assembly**

**SEMICONDUCTOR**

Mark	Symbol & Description	Part No.
★★	IC401	NJM4556S

**CAPACITORS**

Mark	Symbol & Description	Part No.
	C401, C402	CEAS330M16
	C403, C404, C408, C409	CKCYF103Z50
	C406, C407	CQMA104K50
	C405	CKCYF473Z50

**RESISTORS**

Mark	Symbol & Description	Part No.
★	VR401 Variable resistor (PHONES LEVEL) Other resistors	PC1001 RD 1/8 PM □ □ □ J

**OTHERS**

Mark	Symbol & Description	Part No.
	JA2 Phone jack (PHONES)	RK1001

**⚠ Transformer Board Assembly**

**CAPACITORS**

<u>Mark</u>	<u>Symbol &amp; Description</u>	<u>Part No.</u>
	C302-C311	CKCYF103Z50

**⚠ SW board Assembly**

**SWITCH**

<u>Mark</u>	<u>Symbol &amp; Description</u>	<u>Part No.</u>
⚠★★	S301 Power switch	PSA-009

**CAPACITOR**

<u>Mark</u>	<u>Symbol &amp; Description</u>	<u>Part No.</u>
⚠	C301 (0.01 $\mu$ F/AC250V)	RCG-009



# 10. ADJUSTMENT

The adjustments for this unit are shown below. Adjustments must be made in the order in which they are listed.

## ● ADJUSTMENTS

1. Tracking error offset, focus offset and RF offset adjustment
2. RF level adjustment
3. LD (laser diode) power check
4. Focus lock and spindle lock check
5. Grating adjustment (1), (2)
6. Tracking balance adjustment
7. Tangential adjustment
8. Focus gain adjustment
9. Tracking gain adjustment
10. VCO free run frequency adjustment
11. Focus error check
12. MSB adjustment

## ● REQUIRED EQUIPMENT

1. Dual trace oscilloscope
2. Optical power meter
3. Test disc (YEDS-7)
4. Loop gain adjustment filter
5. Signal generator
6. Frequency counter
7. Other commonly used measuring equipment

## ● ABOUT THE TEST MODE

All adjustments must be carried out with the unit in the test mode.

### Activating and releasing the test mode

- (1) To activate the test mode, turn ON the power switch (S301) with the test mode switch (S1) in the ON position.
- (2) The test mode is released by turning the power switch OFF.

The functions for the keys in the test mode are outlined in Table 10-1.

## ● ADJUSTMENT VRs AND THEIR NAMES

- VR1: Laser power
- VR2: RF offset (RF.OFS)
- VR3: Focus gain (FCS.GAN)
- VR4: Tracking gain (TRK.GAN)
- VR5: Tracking balance (TRK.BAL)
- VR6: Focus offset (FCS.OFS)
- VR7: Tracking offset (TRK.OFS)
- VR8: VCO adjust (VCO.ADJ)
- VR9: MSB adjust R-CH (MSB.ADJ-R)
- VR10: MSB adjust L-CH (MSB.ADJ-L)

### Adjusting point

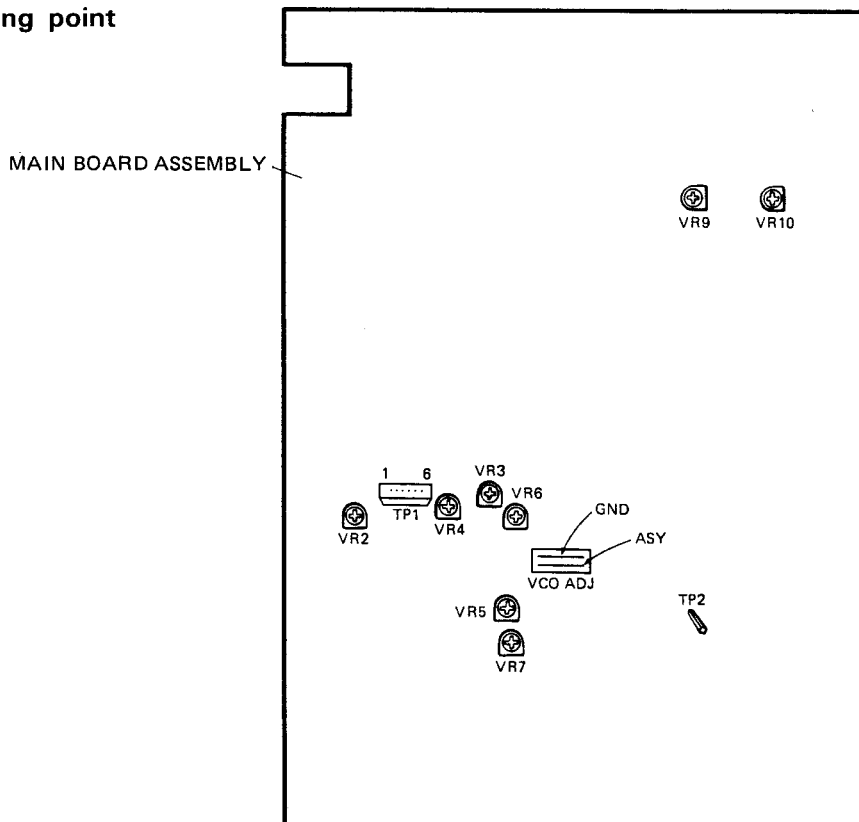

In the test mode, the servos must be closed and opened individually. Consequently, the servos must each be closed in the proper sequence (serial sequence) in order to put the machine into the play mode. Note also that during test mode the unit will not enter the play mode when the PAUSE (⏸) key is pressed alone.

For example, in order to change from the stop to the play mode, the function keys must be pressed in the following order:

\* In the test mode, the servos must be operated in serial sequence.

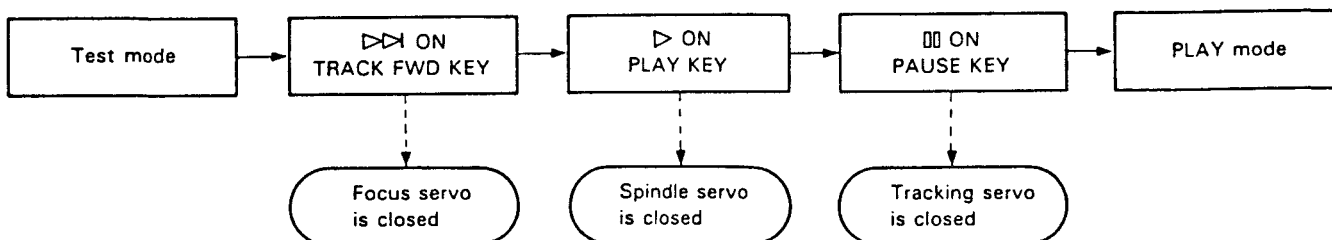

● KEY FUNCTIONS IN THE TEST MODE

Symbol	Key name	Function in test mode	Description
▷◁	TRACK FWD	Focus servo close	Turns ON the laser diode, and raises and lowers the focusing actuator to close the focus servo.
▷	PLAY	Spindle servo close	Closes the servo in the CLV-A mode after kicking the spindle motor.
⏸	PAUSE	Tracking servo close/open	Acts as toggle: closes the tracking servo and activates play mode when pressed (provided the focus and spindle servos are closed), at which time the PAUSE indicator illuminates; opens the tracking servo when pressed again.
▷◁	MANUAL SEARCH REV	Carriage reverse (moves inward)	Moves carriage quickly (3 cm/s) toward inner-most track. Be careful not to move too far as there is no safety device to stop the carriage.
▷◁	MANUAL SEARCH FWD	Carriage forward (moves outward)	Moves carriage quickly (3 cm/s) toward outer-most track. Be careful not to move too far as there is no safety device to stop the carriage.
□	STOP	Stop	Stops all servos and returns system to its initial state.
⏏	OPEN/CLOSE	Disc tray open/close	Opens and closes the disc tray. However, pickup does not return to rest on OPEN, and it remains stationary on CLOSE.

Table 10-1

Step No.	Oscilloscope Setting		Test Points	Adjusting Points	Check items/Adjustment specifications	Adjustment procedure
	V	H				
<b>1</b>	<b>Tracking error offset, focus offset and RF offset adjustment</b>					
			TP1 Pin 2 (TRK.ERR) TP1 Pin 6 (FCS.ERR) TP1 Pin 1 (RF. OUTPUT)	VR5 (TRK.BAL) VR7 (TRK.OFS)  VR6 (FCS.OFS)  VR2 (RF.OFS)	Tracking error offset 45° 0V±50 mV  Focus offset 0V±50 mV  RF offset 100 mV±50 mV	<ul style="list-style-type: none"> <li>● Set the unit to test mode (see page 35).</li> <li>● Set VR5 TRK.BAL (tracking balance) to the position about 45° to the left of center.</li> <li>● Adjust VR7 TRK.OFS (tracking offset) so that the TRK.ERR (tracking error) voltage at TP1 Pin 2 becomes 0V±50 mV.</li> <li>● Adjust VR6 FCS.OFS (focus offset) so that the FCS.ERR (focus error) voltage at TP1 Pin 6 becomes 0V±50 mV.</li> <li>● Adjust VR2 RF.OFS (RF offset) so that the RF output voltage at TP1 Pin 1 becomes 100 mV±50 mV.</li> </ul> <p>Note: When adjusting the tracking error offset, always perform "6. Tracking Balance Adjustment."</p>
<b>2</b>	<b>RF level adjustment</b>					
			TP1 Pin 1 (RF OUTPUT)	VR1 (Laser power)	1.8V±0.1V	<ul style="list-style-type: none"> <li>● Set the unit to test mode (see page 35).</li> <li>● Play the test disc, connect the oscilloscope to TP1 Pin 1 (RF output), and measure the P-P voltage of the RF waveform.</li> <li>● Check that the voltage is 1.8V±0.1V</li> </ul>
<b>3</b>	<b>LD (laser diode) power check</b>					
					Less than 0.13 mW	<ul style="list-style-type: none"> <li>● Set the unit to test mode (see page 35).</li> <li>● Press the TRACK FWD (▶▶) key to turn ON the LD (laser diode).</li> <li>● Place the sensor of the optical power meter directly above the objective lens and confirm that LD power is less than 0.13 mW.</li> </ul>

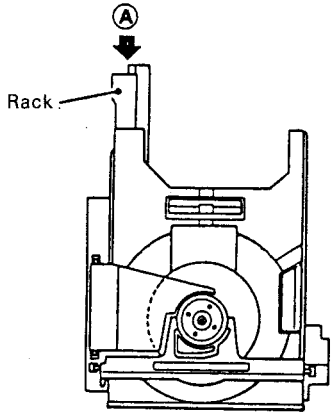
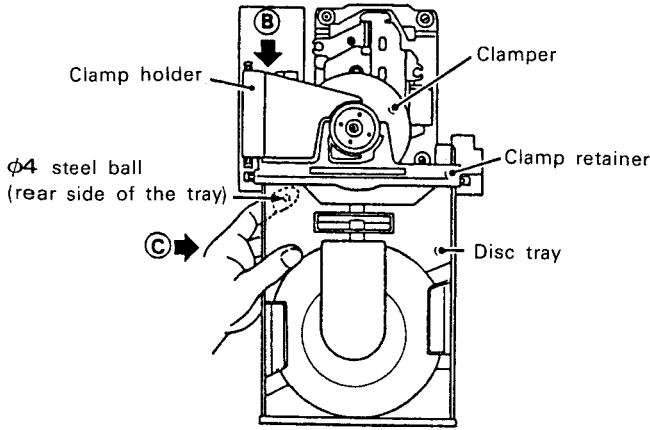
Step No.	Oscilloscope Setting		Test Points	Adjusting Points	Check items/Adjustement specifications	Adjustment procedure
	V	H				
<b>4</b>	<b>Focus lock and spindle lock check</b>					
	V 0.5V/div	H 100 msec/div.	TP1 Pin 1 (RF output)		RF signal is output  Forward (clockwise) rotation	<ul style="list-style-type: none"> <li>● Set the test disc.</li> <li>● Set the unit to test mode (see page 35).</li> <li>● Press the MANUAL SEARCH FWD (▷▷) key to move the pickup to the center of the disc.</li> <li>● Observe the output (RF output) of TP1 Pin 1 on the oscilloscope. Confirm that the RF signal is output after the TRACK FWD (▷▷) key is pressed.</li> <li>● Press the PLAY (▷) key and confirm that the disc rotates at constant speed (approx. 300 rpm near center of disc) in the forward (clockwise) direction; make sure that the disc does not rotate too fast or counterclockwise.</li> </ul>
<b>5</b>	<b>Grating adjustment (1)</b>					
	 <p style="text-align: center;">Fig. 10-1</p>				<p>Remove the disc tray before beginning this adjustment.</p> <ul style="list-style-type: none"> <li>● <b>Removal of the disc tray</b></li> </ul>	
	 <p style="text-align: center;">Fig. 10-2</p>				<ol style="list-style-type: none"> <li>1. Press the rear edge of the rack, marked (A) in Fig. 10-1., while pulling the disc tray out to the position where it catches, illustrated in Fig. 10-2.</li> <li>(*1) When the rear section of the rack (arrow (A)) is pressed, first the disc clamp is released. To slide out the disc tray fully, continue to press after the clamp has been released.</li> <li>2. While pulling the clamp holder (B) (see Fig. 10-2.) upward with the right hand, hold the tray as indicated by (C) in the left hand and pull it outward. Take care not to allow the φ4 steel ball to fall out (it is recommended to hold the ball in place with the left index finger while extracting the tray).</li> </ol>	

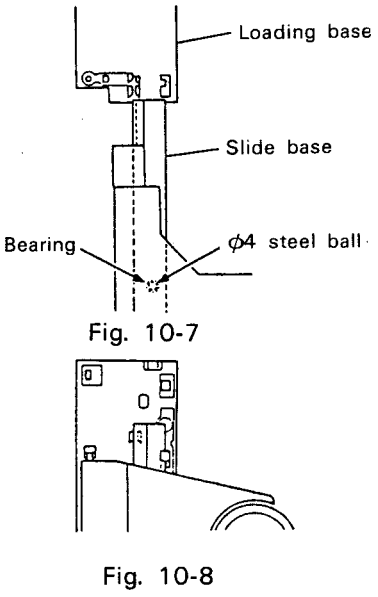

Step No.	Oscilloscope Setting		Test Points	Adjusting Points	Check items/Adjustement specifications	Adjustment procedure
	V	H				
	0.5V/div	5 msec/div	TP1 Pin 2 (TRK.ERR)	Grating adjustment screw Grating adjustment screw	Null point Max. amplitude	<ul style="list-style-type: none"> <li>• Turn the grating adjustment screw with the ⊖ screwdriver to find the null point (see Photo 10-1.).</li> <li>• Next, slowly rotate the screw counterclockwise and adjust to the point where the waveform (tracking error signal) first achieves its maximum amplitude (see Photo 10-3.).</li> </ul> <p>Note: Avoid applying pressure to the screwdriver while adjusting the screw. Doing so causes the pickup to move inward, making adjustment more difficult.</p> <ul style="list-style-type: none"> <li>• Lastly, remove the low pass filter and confirm that the tracking error signal p-p voltage does not greatly vary when the pickup is moved to the inner-most and outer-most tracks of the disc.</li> </ul> <p>If the levels diverge by ±10% or more re-adjust the maximum error amplitude point by rotating the grating adjustment screw.</p>
 <p>Fig. 10-7</p> <p>Fig. 10-8</p>						<p>Remount the disc tray according to the following procedure when the grating adjustment is complete.</p> <ol style="list-style-type: none"> <li>1. Remove the disc and the spacer.</li> <li>2. While lifting the clamp holder [marked ② in Fig. 10-2.] with the right hand, hold the tray in the left hand as indicated by ③ and slide the slide base into the hard resin fittings on the loading base as shown in Fig. 10-7. to reinsert the disc tray. (At this time, be sure to hold the <math>\phi 4</math> steel ball in place with the index finger of the left hand.) (Also, be careful that the front panel is not damaged by the bearing of the slide base at the <math>\phi 4</math> steel ball section coming into contact with the panel.)</li> <li>3. Insert the slide base so that it fits into the two hard resin fittings at the rear of the loading base (see Fig. 10-8.).</li> <li>4. Insert the tray all the way.</li> </ol>

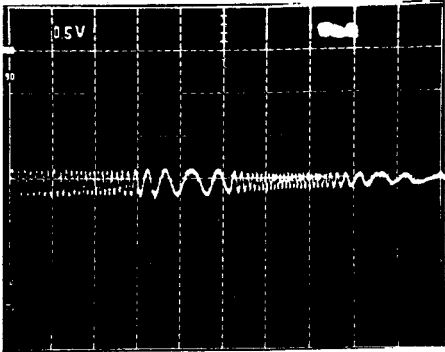

Photo 10-1 Null point

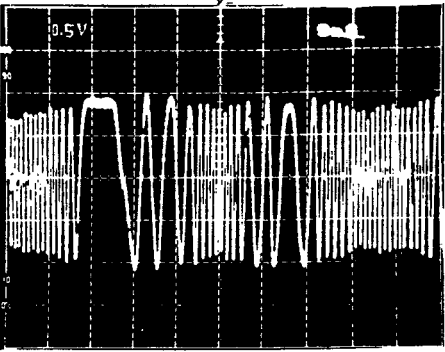

Photo 10-3 Maximum amplitude

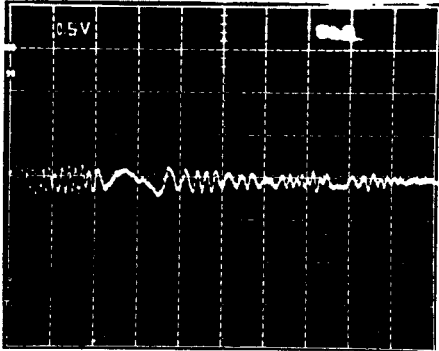
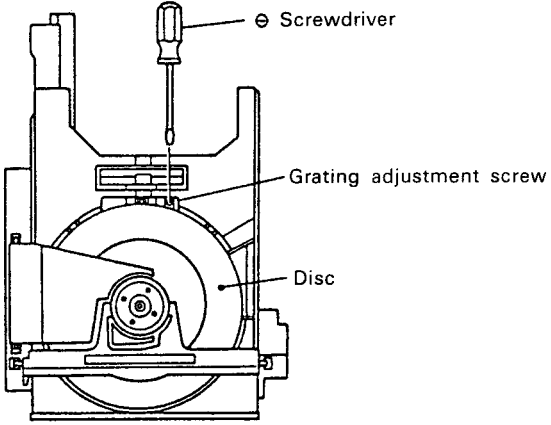
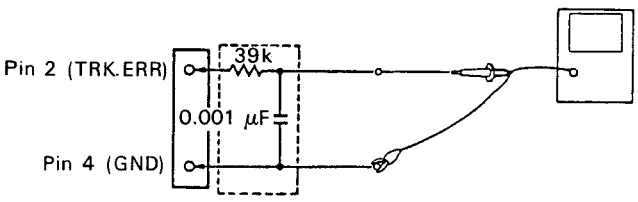
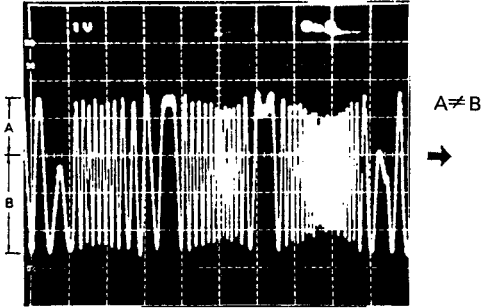
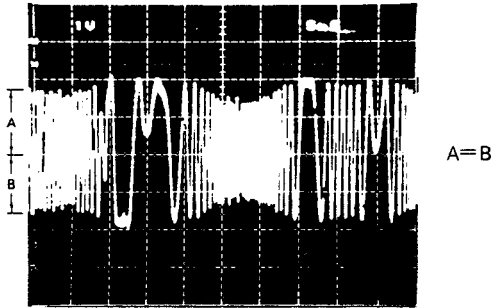
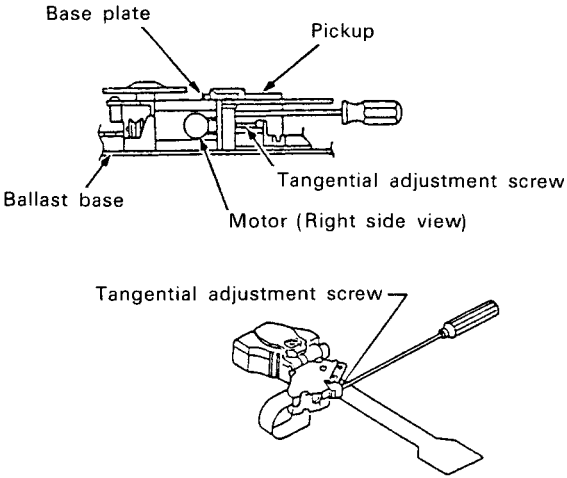
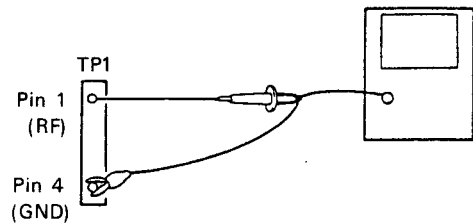

Photo 10-2 This is not the null-point waveform

Step No.	Oscilloscope Setting		Test Points	Adjusting Points	Check items/Adjustement specifications	Adjustment procedure
	V	H				
5	<b>Grating adjustment (2) (using discs with a recording time of 60 min. or more)</b>					
	 <p>Fig. 10-9</p>  <p>Fig. 10-10</p>					<p>Note: This adjustment can only be performed with a disc having pits up to R115mm, not with the Test Disc (YEDS-7).</p> <ul style="list-style-type: none"> <li>• Set the unit to test mode (see page 35).</li> <li>• Load the test disc, shift the pickup to the outer periphery so that the pickup grating adjustment hole is visible from the pit surface of the disc or from the hole in the servo mechanism (see Fig. 10-10.).</li> <li>• Press the TRACK FWD (▷) and the PLAY (▷) keys in sequence to close the focus servo and spindle servo (do not close the tracking servo).</li> <li>• Observe the waveform output by TP1 Pin 2 TRK.ERR (tracking error) on an oscilloscope, inserting a 4 kHz low-pass filter (see Fig 10-10.).</li> </ul>
0.5V/div	5 msec/div	TP1 Pin 2 (TRK.ERR)	Grating  Grating	Null Point  Maximum amplitude	<ul style="list-style-type: none"> <li>• Insert a ⊖ screwdriver into the grating hole, turn and find the null point (see Photo 10-1.).</li> <li>• Next, slowly turn the ⊖ screwdriver counter-clockwise from the null point and adjust until the waveform (tracking error signal) reaches maximum amplitude (see Photo 10-3.).</li> </ul> <p>Note: Use caution since inserting the ⊖ screwdriver forcefully will cause the pickup unit to float upward.</p> <ul style="list-style-type: none"> <li>• Finally, confirm that there is no major fluctuation in the p-p voltage of the tracking error signal (do not insert the cutoff 4 kHz low-pass filter) when the pickup is shifted to the inner periphery and when the pickup is shifted to the outer periphery. If there is a difference of more than ±10% again rotate the grating adjustment screw and adjust the tracking error signal to maximum amplitude point.</li> </ul>	



Step No.	Oscilloscope Setting		Test Points	Adjusting Points	Check items/Adjustment specifications	Adjustment procedure
	V	H				
<b>6 Tracking balance adjustment</b>						
	0.5V/div	5 msec/div	TP1 Pin 2 (TRK.ERR)	VR5 (TRK.BAL)		<ul style="list-style-type: none"> <li>● Load the test disc.</li> <li>● Set the unit to test mode (see page 35).</li> <li>● Press the MANUAL SEARCH FWD (▷▷) key to position the pickup near the center of the disc.</li> <li>● Press the TRACK FWD (▷▷) and PLAY (▷) keys sequentially to cause the disc to rotate.</li> <li>● Observe the waveform output by TP1 Pin 2 TRK.ERR (tracking error) on the oscilloscope and adjust VR5 TRK.BAL (tracking balance) so that the DC components are eliminated from the tracking error signal.</li> </ul>
			<p style="text-align: center;"><math>A \neq B</math></p>			
	Photo 10-4 DC elements mixed in signal					Photo 10-5 DC elements eliminated
<b>7 Tangential adjustment</b>						
						<ul style="list-style-type: none"> <li>● Set the unit to test mode (see page 35).</li> <li>● Open the tray and load the test disc.</li> <li>● Press the MANUAL SEARCH FWD (▷▷) key to position the pickup near the center of the disc.</li> <li>● Insert a hex wrench into the tangential adjustment screw section from the rear of the mechanism.</li> <li>● Close the tray.</li> </ul> <p>Note: An L-shaped hex wrench should not be used. Use one such as shown on the left. If an L-shaped hex wrench is to be used, the tray must be removed before performing adjustment (see page 39, 5. Grating Adjustment (1)).</p> <ul style="list-style-type: none"> <li>● Press the TRACK FWD (▷▷), PLAY (▷), and PAUSE (⏸) keys sequentially to close all the servos (the pause indicator will illuminate).</li> </ul>
	Fig. 10-11					

Step No.	Oscilloscope Setting		Test Points	Adjusting Points	Check items/Adjustement specifications	Adjustment procedure
	V	H				
		200 nsec/div	TP1 Pin 1 (RF output)	Tangential adjustment screw	Sharpest possible eye pattern	<ul style="list-style-type: none"> <li>● Observe the waveform output by TP1 Pin 1 (RF output) on the oscilloscope and adjust the tangential adjustment screw to achieve the sharpest possible eye pattern.</li> <li>● The point to which the adjusting screw should be set lies about halfway between the points where the eye pattern becomes most blurred when the screw is rotated clockwise and counterclockwise. When the whole waveform becomes clear, concentrate on sharpening the fine lines forming the diamond at the center of the eye pattern (see Photo 10-8.). Adjust until the fine lines on all four sides of the diamond are both sharply defined and dense.</li> </ul> <div style="text-align: center;">  <p>Fig. 10-12</p> <p>Note: Use a hex wrench to raise the pickup somewhat while making this adjustment.</p> </div>

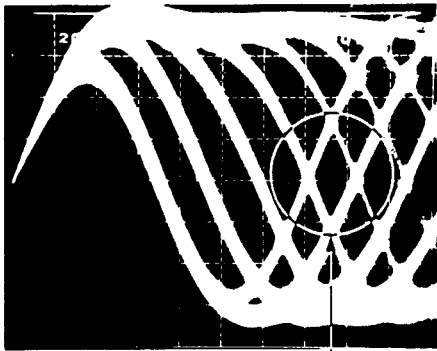

Part to be observed

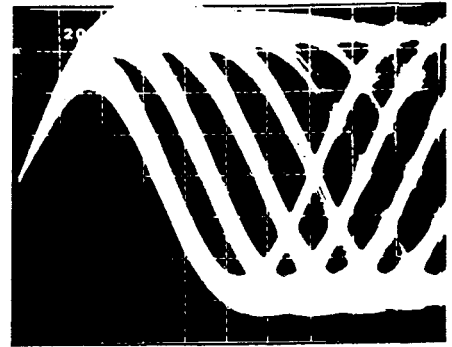
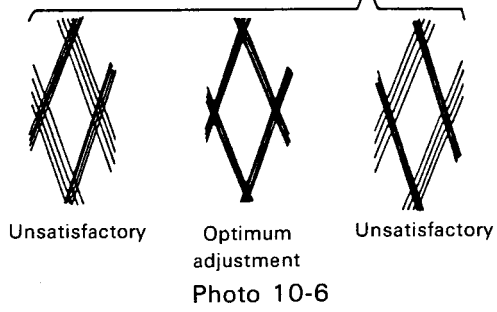

Photo 10-7

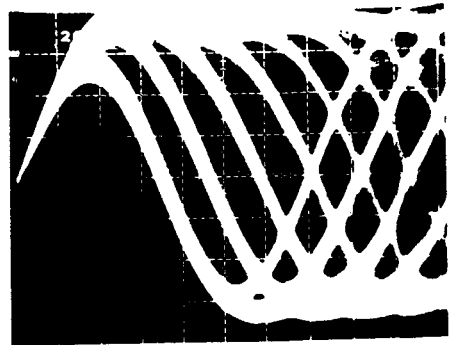
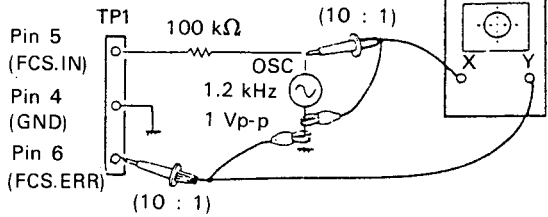
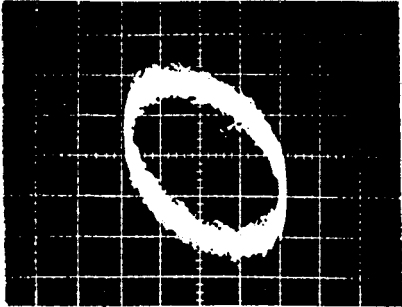
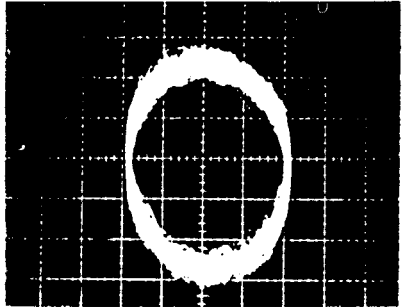
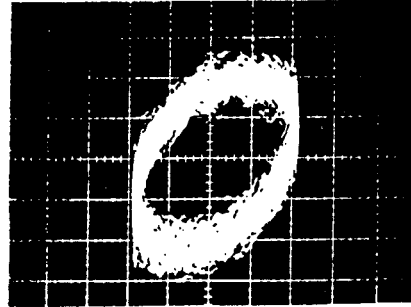

Photo 10-8



Photo 10-9

Step No.	Oscilloscope Setting		Test Points	Adjusting Points	Check items/Adjustement specifications	Adjustment procedure
	V	H				
<b>8</b>	<b>Focus gain adjustment</b>					
	CH1 (X), CH2 (Y) 20 mV/div 5 mV/div (probe: 10:1)		X-axis TP1 Pin 5 (FCS. IN) Y-axis TP1 Pin 6 (FCS. ERR)	VR3 (FCS. GAN)	Phase difference of 90	<ul style="list-style-type: none"> <li>With the oscillator power turned OFF, connect the oscilloscope and oscillator as shown in Fig. 10-13.</li> <li>Set the unit to test mode (see page 35).</li> <li>Press the TRACK FWD (▶▶), PLAY (▶) and PAUSE (⊞) keys sequentially to close the focus, spindle and tracking servos.</li> <li>Turn ON the power to the oscillator and set it to output a 1.2 kHz 1 Vp-p signal.</li> </ul> <p>Note: Some oscillators discharge a DC voltage when turned on. It is therefore recommended that the oscillator be connected after it has been turned on.</p> <ul style="list-style-type: none"> <li>Adjust VR3 FCS.GAN (focus gain) so that the Lissajous's figure becomes a horizontal circle on the oscilloscope (phase difference of 90°).</li> </ul>
						 <p style="text-align: center;">Fig. 10-13</p>
						Gain overcompensated Photo 10-10
						Gain optimal Photo 10-11
						Gain undercompensated Photo 10-12

Step No.	Oscilloscope Setting		Test Points	Adjusting Points	Check items/Adjustement specifications	Adjustment procedure
	V	H				
<b>9 Tracking gain adjustment</b>						
	CH1(X), CH2(Y) 50 mV/div, 5 mV/div (probe: 10:1)	X-axis TP1 Pin 3 (TRK.IN) Y-axis TP1 Pin 2 (TRK.OUT)	VR4 (TRK.GAN)	Phase difference of 90°	<ul style="list-style-type: none"> <li>With the oscillator power turned OFF, connect the oscilloscope and oscillator as shown in Fig. 10-14.</li> <li>Set the unit to test mode (see page 35).</li> <li>Press the TRACK FWD (▶▶), PLAY (▶) and PAUSE (⏸) keys sequentially to close the focus, spindle and tracking servos.</li> <li>Turn ON the power to the oscillator and set it to output a 1.2 kHz 2 Vp-p signal.</li> </ul> <p>Note: Some oscillators discharge a DC voltage when turned on. It is therefore recommended that the oscillator be connected after it has been turned on.</p> <ul style="list-style-type: none"> <li>Adjust VR4 TRK.GAN (tracking gain) so that the Lissajous' figure becomes a horizontal circle on the oscilloscope (phase difference of 90°).</li> </ul>	<p style="text-align: center;">Fig. 10-14</p>
<div style="display: flex; justify-content: space-around;"> <div style="text-align: center;"> <p>Gain overcompensated Photo 10-13</p> </div> <div style="text-align: center;"> <p>Gain optimal Photo 10-14</p> </div> <div style="text-align: center;"> <p>Gain undercompensated Photo 10-15</p> </div> </div>						

Step No.	Oscilloscope Setting		Test Points	Adjusting Points	Check items/ Adjustment specifications	Adjustment procedure
	V	H				
<b>10</b>	<b>VCO free run frequency adjustment</b>					
			TP2 Pin 2	VR8 (VCO.ADJ)	4.275 ±0.025 MHz	<ul style="list-style-type: none"> <li>Set the unit to test mode (see page 35).</li> <li>Short the ASY and GND jumper with a ⊖ screwdriver or similar tool (see Fig. 10-15.).</li> <li>Connect a frequency counter capable of measuring frequencies of 10 MHz and above to TP2 Pin 2.</li> <li>Adjust VR8 VCO.ADJ (VCO free run adjustment) so that the frequency counter reading becomes 4.275±0.025 MHz.</li> </ul>
<b>11</b>	<b>Focus error check</b>					
			TP1 Pin 6 (FCS.ERR)			<ul style="list-style-type: none"> <li>Set the unit to test mode (see page 35).</li> <li>Ground TP1 Pin 5 FCS.IN (focus in) to GND.</li> <li>Observe the waveform output by TP1 Pin 6 FCS.ERR (focus error) when the TRACK FWD (▶) key is pressed.</li> </ul>

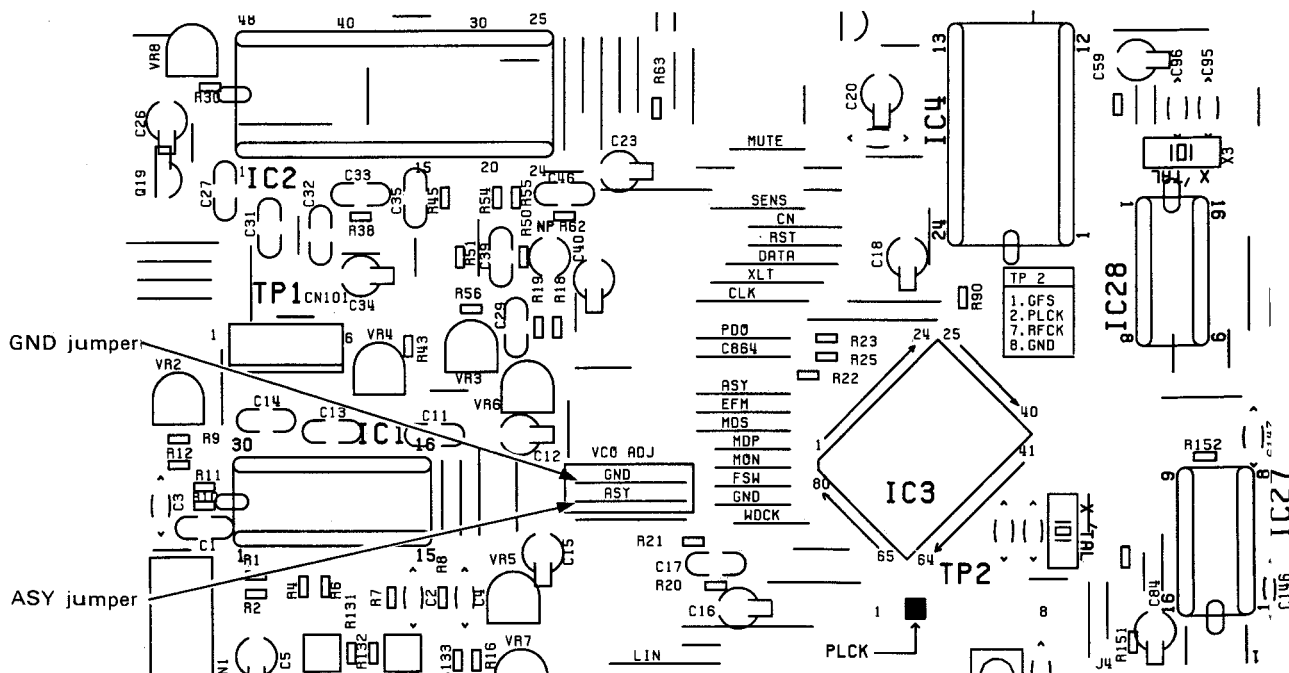
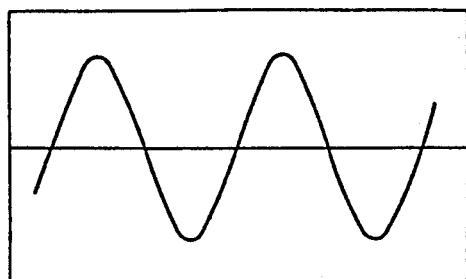

Fig. 10-15 Positions of ASY and GND jumpers

Step No.	Oscilloscope Setting		Test Points	Adjusting Points	Check items/Adjustment specifications	Adjustment procedure
	V	H				
<b>12</b>	<b>MSB adjustment</b>					
	5mV/div	0.2 msec/div	JA1 LINE OUT terminal (Lch)	VR10	Sine wave	<ul style="list-style-type: none"> <li>Set the unit to normal play mode.</li> <li>Play back the 20th track (-60 dB, 1 kHz, L/Rch) of the test disc (YEDS-7). Connect an oscilloscope to L ch of the LINE OUT terminals and observe the audio output waveform.</li> <li>Adjust VR10 MSB.ADJ Rch (MSB adjust, right channel) so that the waveform on the oscilloscope becomes a sine wave.</li> <li>Perform the same adjustment for L-CH (VR9).</li> </ul>
			JA1 LINE OUT terminal (Rch)	VR9	Sine wave	

● Zero cross distortion waveform



OK

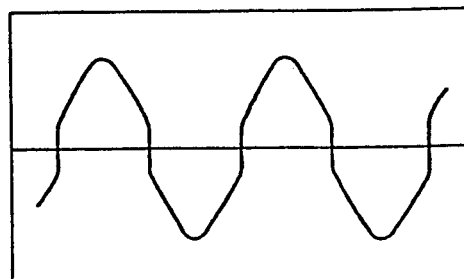

NG

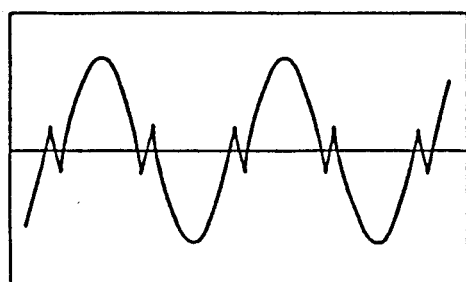

NG

## 10. RÉGLAGE

On trouvera ci-après les réglages requis pour cet appareil. Ils doivent être exécutés dans l'ordre donné.

### ● AJUSTEMENTS

1. Ajustement de décalage d'erreur d'alignement, de décalage de mise au point et de décalage RF
2. Vérification de niveau RF
3. Vérification d'alimentation LD (diode laser)
4. Vérification de verrouillage de mise au point et de verrouillage d'axe
5. Ajustement de grille (1), (2)
6. Ajustement d'équilibre d'alignement
7. Ajustement tangentiel
8. Ajustement de gain de mise au point
9. Ajustement de gain d'alignement
10. Ajustement de fréquence libre VCO
11. Vérification d'erreur de mise au point
12. Ajustement MBS

### ● EQUIPEMENTS NECESSAIRES

1. Oscilloscope à double tracé
2. Wattmètre optique
3. Disque d'essai (YEDS-7)
4. Filtre d'ajustement de gain de boucle
5. Générateur de signal
6. Fréquencemètre
7. Autres équipements de mesure généralement utilisés

### ● A PROPOS DU MODE D'ESSAI

Tous les réglages doivent être effectués, l'appareil se trouvant en mode d'essai.

#### Activation et annulation du mode d'essai

- (1) Pour activer le mode d'essai, allumer (ON) l'interrupteur d'alimentation (S301) après avoir placé l'interrupteur de mode d'essai (S1) à la position ON.
- (2) Le mode d'essai est annulé en ramenant l'interrupteur d'alimentation sur OFF.

Les fonctions des touches du mode d'essai sont décrites au Tableau 10-1.

### ● DISPOSITIFS D'AJUSTEMENT ET NOMENCLATURE

- VR1: Alimentation laser
- VR2: Décalage RF (RF.OFS)
- VR3: Gain de mise au point (FCS.GAN)
- VR4: Gain d'alignement (TRK.GAN)
- VR5: Equilibrage d'alignement (TRK.BAL)
- VR6: Décalage de mise au point (FCS.OFS)
- VR7: Décalage d'alignement (TRK.OFS)
- VR8: Ajustement VCO (VCO.ADJ)
- VR9: Ajustement MSB Canal droit (MSB.ADJ-R)
- VR10: Ajustement MSB Canal gauche (MSB.ADJ-L)

#### Point de réglage

MONTAJE DEL TABLERO PRINCIPAL

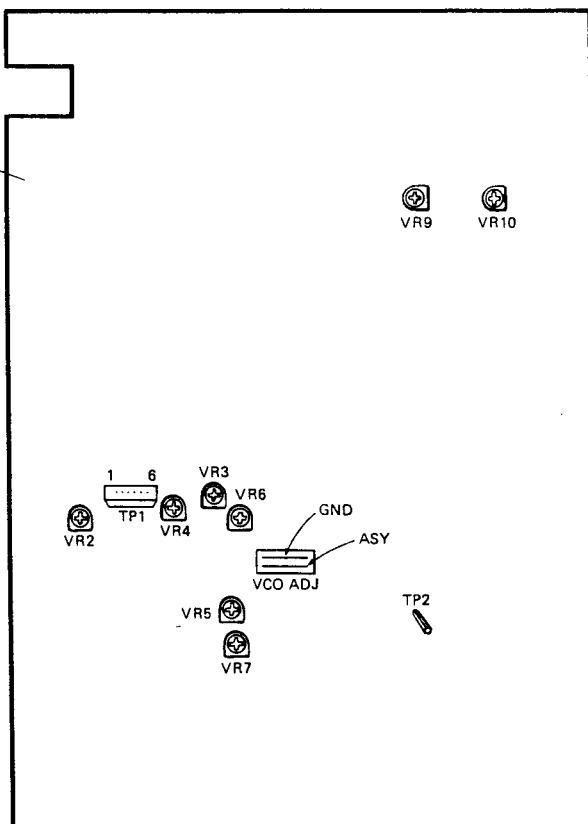



En mode d'essai, les servos doivent être individuellement fermés et ouverts. En conséquence, les servos doivent chacun être fermés dans la séquence correcte (séquence sérielle) afin de placer l'appareil en mode de lecture. Remarque également que pendant le mode d'essai, l'appareil ne se placera pas en mode de lecture par une

pression sur la seule touche PAUSE (⏸).

Par exemple, pour passer du mode d'arrêt au mode de lecture, les touches de fonction doivent être actionnées dans l'ordre suivant:

\* En mode d'essai, les servos doivent être opérés en séquence sérielle.

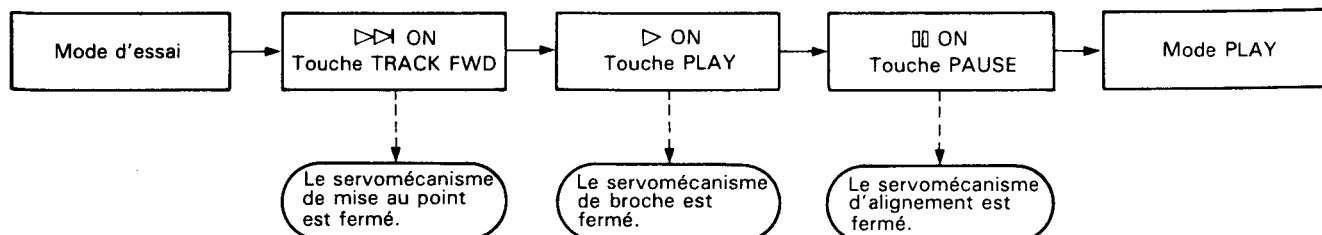

### ● FONCTIONS DES TOUCHES EN MODE D'ESSAI

Symbole	Nom de touche	Fonction en mode d'essai	Description
↔	TRACK FWD	Servo de mise au point fermé	Allume la diode laser et élève ou abaisse le dispositif de commande de mise au point pour fermer le servo de mise au point.
▷	PLAY	Servo d'axe fermé	Ferme le servo en mode CLV-A après cognement du moteur d'axe.
⏸	PAUSE	Fermeture/ouverture de servo d'alignement	Agit comme interrupteur articulé: ferme le servo d'alignement et active le mode de lecture quand poussé (à condition que les servos de mise au point et d'axe soient fermés), auquel moment le témoin PAUSE s'allume; ouvre le servo d'alignement à la pression suivante.
↔	MANUAL SEARCH REV	Inversion du chariot (déplacement vers l'intérieur)	Déplace rapidement (3 cm/sec) le chariot vers la plage la plus au centre. Prendre garde à ne pas déplacer trop loin, car il n'existe pas de dispositif de sécurité pour arrêter le chariot.
↔	MANUAL SEARCH FWD	Avance du chariot (déplacement vers l'extérieur)	Déplace rapidement (3 cm/sec) le chariot vers la plage la plus à l'extérieur. Prendre garde à ne pas déplacer trop loin, car il n'existe pas de dispositif de sécurité pour arrêter le chariot.
□	STOP	Arrêt	Arrête tous les servos et ramène le système à son état initial.
⏏	OPEN/CLOSE	Ouverture/fermeture de plateau de disque	Ouvre et ferme le plateau du disque. Cependant, le capteur ne revient pas à la position de repos à OPEN et il reste stationnaire à CLOSE.

Tableau 10-1.

N° d'étape	Réglage d'oscilloscope		Points d'essai	Points de réglage	Postes de contrôle/Spécifications de réglage	Procédure de réglage
	V	H				
<b>1</b>	<b>Ajustement de décalage d'erreur d'alignement, de décalage de mise au point et de décalage RF</b>					
			TP1 Broche 2 (TRK.ERR) TP1 Broche 6 (FCS.ERR) TP1 Broche 1 (RF OUTPUT)	VR5 (TRK. BAL) VR7 (TRK. OFS)  VR6 (FCS.OFS)  VR2 (RF.OFS)	Décalage d'erreur d'alignement 45° 0V±50 mV  Décalage de mise au point 0V±50 mV Décalage RF 100 mV±50 mV	<ul style="list-style-type: none"> <li>Placer l'appareil en mode d'essai (voir page 50).</li> <li>Régler VR5 TRK.BAL (équilibrage d'alignement) à la position environ à 45° à la gauche du centre.</li> <li>Ajuster VR7 TRK.OFS (décalage d'alignement) de sorte que la tension TRK.ERR (erreur d'alignement) à TP1 broche 2 devienne 0V±50 mV.</li> <li>Ajuster VR6 FCS.OFS (décalage de mise au point) de sorte que la tension FCS.ERR (erreur de mise au point) à TP1 broche 6 devienne 0V±50 mV.</li> <li>Ajuster VR2 RF.OFS (décalage RF) de sorte que la tension de sortie RF à TP1 broche 1 devienne 100 mV±50 mV.</li> </ul> <p>Remarque: Lors de l'ajustement du décalage d'erreur d'alignement, effectuer toujours "6. Ajustement d'équilibrage d'alignement".</p>
<b>2</b>	<b>RF level adjustment</b>					
			TP1 Broche 1 (RF OUTPUT)	VR1 (Alimentation laser)	1.8V±0.1V	<ul style="list-style-type: none"> <li>Placer l'appareil en mode d'essai (voir page 50).</li> <li>Reproduire le disque d'essai, raccorder l'oscilloscope à TP1 broche 1 (sortie RF), et mesurer la tension c-c de la forme d'onde RF.</li> <li>Vérifier que le voltage est de 1.8V±0.1V.</li> </ul>
<b>3</b>	<b>Vérification d'alimentation LD (diode laser)</b>					
					Inférieure à 0,13 mW	<ul style="list-style-type: none"> <li>Placer l'appareil en mode d'essai (voir page 50).</li> <li>Appuyer sur la touche TRACK FWD (▷▷) pour allumer la diode laser.</li> <li>Placer le senseur du wattmètre optique directement au-dessus de l'objectif et confirmer que l'alimentation LD est inférieure à 0,13 mW.</li> </ul>

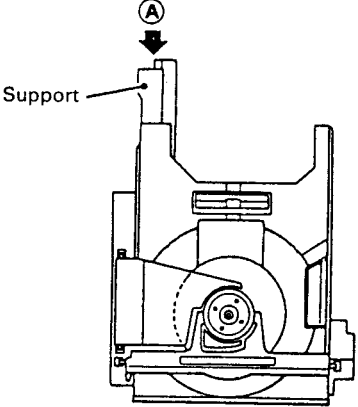
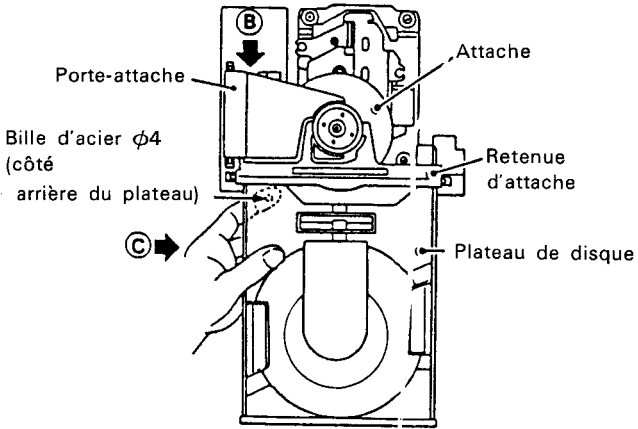
N° d'étape	Réglage d'oscilloscope		Points d'essai	Points de réglage	Postes de contrôle/Spécifications de réglage	Procédure de réglage
	V	H				
4	<b>Vérification de verrouillage de mise au point et de verrouillage d'axe</b>					
	V 0,5V/div	H 100 ms/div	TP1 Broche 1 (Sortie RF)		Le signal RF est fourni  Rotation avant (sens des aiguilles)	<ul style="list-style-type: none"> <li>• Installer le disque d'essai.</li> <li>• Placer l'appareil en mode d'essai (voir page 50).</li> <li>• Appuyer sur la touche MANUAL SEARCH FWD (▷▷) pour amener le cap-teur au centre du disque.</li> <li>• Observer la sortie (sortie RF) de TP1 broche sur l'oscilloscope. Confirmer que le signal haute fréquence est fourni après une pression sur la touche TRACK FWD (▷▷).</li> <li>• Appuyer sur la touche PLAY (▷) et confirmer que le disque tourne à vitesse constante (env. 300 tr/mn près du centre du disque) dans le sens avant (sens des aiguilles); s'assurer que le disque ne tourne pas trop vite ou tourne dans le sens contraire des aiguilles.</li> </ul>
5	<b>Ajustement de grille (1)</b>					
	 <p>Fig. 10-1</p>				<p>Retirer le disque du plateau avant de commencer cet ajustement.</p> <ul style="list-style-type: none"> <li>• <b>Retrait du plateau de disque</b></li> </ul>	
	 <p>Fig. 10-2</p>				<ol style="list-style-type: none"> <li>1. Appuyer sur le bord arrière du support, à l'endroit marqué (A) sur la Fig. 10-1, tout en retirant le plateau de disque vers la position où il tient, comme illustré sur la Fig. 10-2. (*1) Lorsque la section arrière du support (flèche (A)) est enfoncée, l'attache de disque est relâchée en premier. Pour faire glisser le plateau de disque entièrement vers l'extérieur, continuer à appuyer après le relâchement de l'attache.</li> <li>2. Tout en tirant le porte-attache (B) (voir Fig. 10-2) vers le haut de la main droite, tenir le plateau comme indiqué par (C) de la main gauche et le tirer vers l'extérieur. Prendre garde à ne pas laisser tomber la bille d'acier φ4 (il est conseillé de maintenir la bille en place avec l'index a uche tout en extrayant le plateau).</li> </ol>	

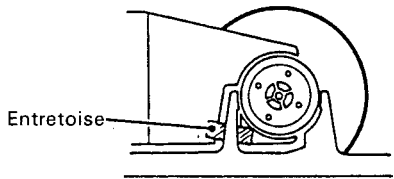
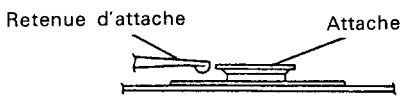
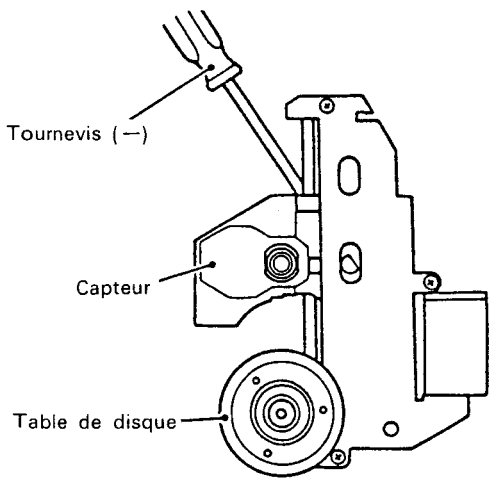
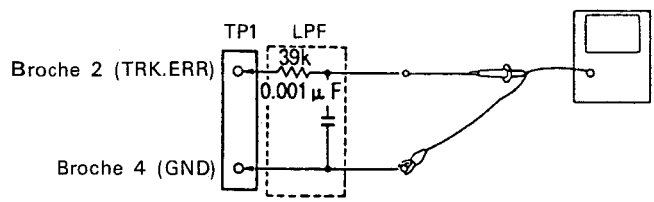
N° d'étape	Réglage d'oscilloscope		Points d'essai	Points de réglage	Postes de contrôle/Spécifications de réglage	Procédure de réglage
	V	H				
						
						
						<ul style="list-style-type: none"> <li>● Placer l'appareil en mode d'essai (voir page 50).</li> <li>● Appuyer sur la touche MANUAL SEARCH FWD (&gt;&gt;) pour amener le cap-teur près de l'endroit qui devrait être le centre du disque. Positionner le capteur de sorte que sa vis d'ajustement de grille soit visible par l'orifice allongé sur le côté du moteur d'axe de la plaque de base sur servo-mécanisme.</li> <li>● Comme illustré sur la Fig. 10-5, introduire un tournevis <math>\ominus</math> (tournevis de précision de 2 mm) par l'arrière du mécanisme et vérifier que la vis d'ajustement de grille peut être tournée.</li> <li>● Installer le disque d'essai; veiller à insérer une entretoise de 3-5 mm (si aucune entretoise n'est disponible, se servir d'une clé hexagonale) entre le porte-attache et la retenue d'attache, comme illustré sur la Fig. 10-3.</li> <li>● Confirmer que l'attache et la retenue d'attache ne font pas contact l'une sur l'autre (Fig. 10-4).</li> <li>● Appuyer sur les touches TRACK FWD (&gt;&gt;) et PLAY (&gt;) en séquence pour fermer les servos de mise au point et d'axe (ne pas fermer le servo d'alignement).</li> <li>● Installer un filtre passe-bas de coupure à 4 kHz entre l'oscilloscope et TP1 broche 2 (TRK.ERR) et broche 4 (GND), comme illustré sur la Fig. 10-6 et observer la forme d'onde de TP1 broche 2 TRK.ERR (erreur d'alignement) sur l'oscilloscope.</li> </ul>
						

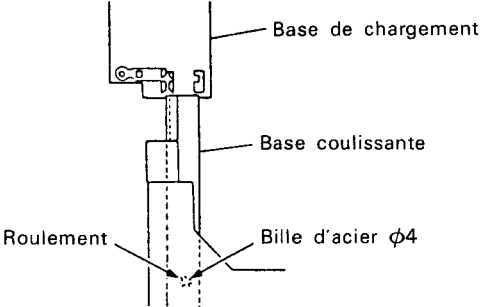
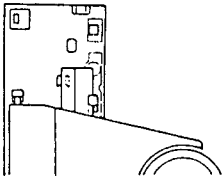
N d'étape	Réglage d'oscilloscope		Points d'essai	Points de réglage	Postes de contrôle/Spécifications de réglage	Procédure de réglage
	V	H				
	0,5V/div	5 ms/div	TP1 Broche 2 (TRK.ERR)	Vis d'ajustement de grille Vis d'ajustement de grille	Point nul  Amplitude maximale	<ul style="list-style-type: none"> <li>• Tourner la vis d'ajustement de grille à l'aide du tournevis <math>\ominus</math> pour trouver le point nul (voir Photo 10-1).</li> <li>• Tourner ensuite lentement la vis dans le sens inverse des aiguilles d'une montre et ajuster au point où la forme d'onde (signal d'erreur d'alignement) arrive en premier à son amplitude maximale (voir Photo 10-3).</li> </ul> <p>Remarque: Eviter d'appliquer une pression au tournevis tout en ajustant la vis pour ne pas déplacer le capteur vers l'intérieur, rendant l'ajustement plus difficile.</p> <ul style="list-style-type: none"> <li>• En dernier lieu, retirer le filtre passe-bas et confirmer que la tension c-c du signal d'erreur d'alignement ne varie pas trop quand le capteur est déplacé au première et dernière plages du disque. Si les niveaux divergent de <math>\pm 10\%</math> ou davantage, réajuster le point d'amplitude d'erreur maximale en agissant sur la vis d'ajustement de grille.</li> </ul>
<div style="display: flex; flex-direction: column; align-items: center;">  <p>Fig. 10-7</p>  <p>Fig. 10-8</p> </div>						<p>Remonter le plateau du disque selon la procédure ci-après après avoir terminé l'ajustement de grille.</p> <ol style="list-style-type: none"> <li>1. Retirer le disque et l'entretoise.</li> <li>2. Tout en levant le porte-attache (marqué par <math>\textcircled{B}</math>) sur la Fig. 10-2) de la main droite, tenir le plateau de la main gauche, comme illustré par <math>\textcircled{C}</math> et déplacer la base coulissante dans les armatures en résine dure sur la base de chargement comme indiqué sur la Fig. 10-7 pour réinsérer le plateau du disque. (A ce moment, prendre soin de tenir la bille d'acier <math>\phi 4</math> en place avec l'index de la main droite.) (Veiller également à ce que le panneau avant ne soit pas endommagé par le roulement de la base coulissante au niveau de la section la bille d'acier <math>\phi 4</math> entrant en contact avec le panneau.)</li> <li>3. Insérer la base coulissante de sorte qu'elle s'engage dans les deux armatures en résine dure à l'arrière de la base de chargement (voir fig. 10-8).</li> <li>4. Insérer à fond le plateau.</li> </ol>

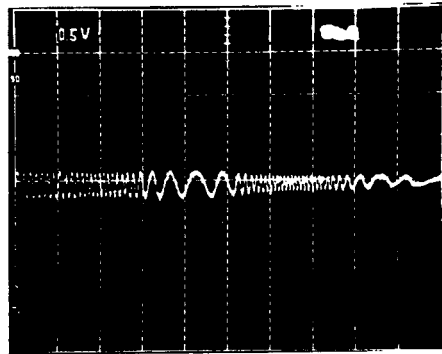

Photo 10-1 Point nul

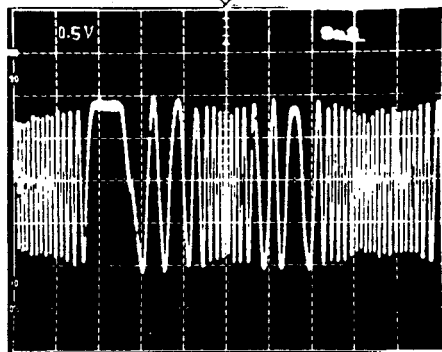

Photo 10-3 Amplitude maximale

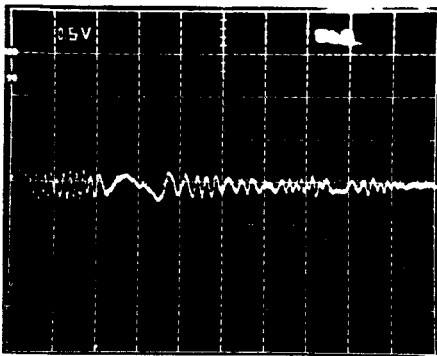
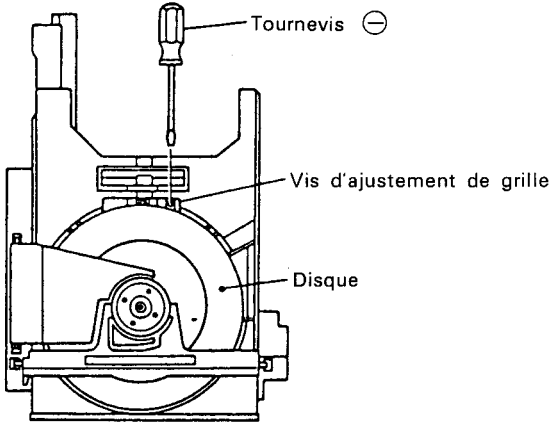
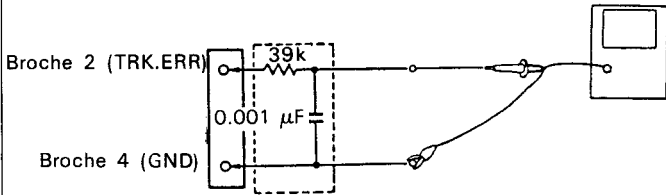
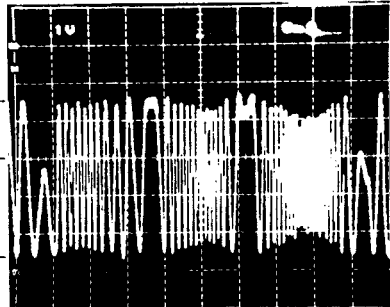
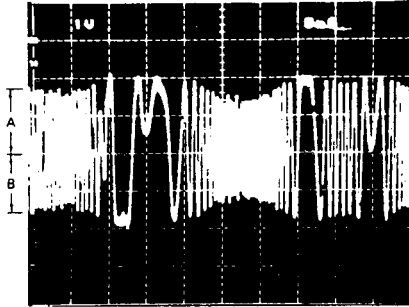
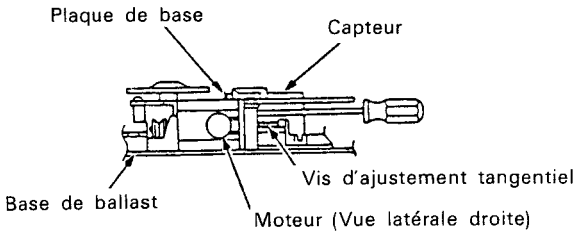
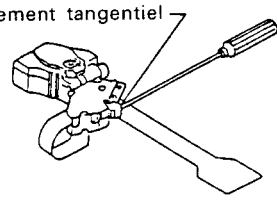
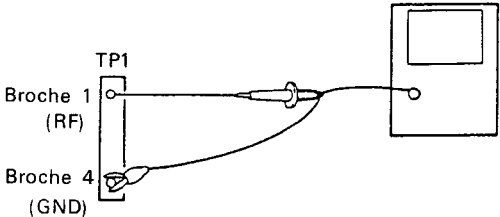

Photo 10-2 Ceci n'est pas la forme d'onde du point nul

N° d'étape	Réglage d'oscilloscope		Points d'essai	Points de réglage	Postes de contrôle/Spécifications de réglage	Procédure de réglage
	V	H				
5	Ajustement de grille (2) (utiliser un disque d'une durée d'enregistrement de 60 min. ou davantage)					
	 <p>Fig. 10-9</p>					<p>Remarque: Cet ajustement ne peut être effectué qu'avec un disque ayant des cavités jusqu'à R115 mm et non pas avec le disque d'essai (YEDS-7).</p> <ul style="list-style-type: none"> <li>● Régler l'appareil en mode d'essai (voir page 50).</li> <li>● Installer le disque d'essai, amener le capteur à la périphérie extérieure de sorte que l'orifice d'ajustement de grille de capteur soit visible de la surface de la cavité du disque ou par l'orifice du servomécanisme (voir Fig. 10-10).</li> <li>● Appuyer sur les touches TRACK FWD (&gt;) et PLAY (&gt;&gt;) en séquence pour fermer les servos de mise au point et d'axe (ne pas fermer le servo d'alignement).</li> <li>● Observer la forme d'onde de TP1 broche 2 TRK.ERR (erreur d'alignement) sur un oscilloscope, en insérant un filtre passe-bas de 4 kHz (voir Fig. 10-10).</li> </ul>
	 <p>Fig. 10-10</p>					<ul style="list-style-type: none"> <li>● Insérer un tournevis <math>\ominus</math> dans l'orifice de grille, le tourner et rechercher le point nul (voir Photo 10-1).</li> <li>● Tourner ensuite lentement le tournevis <math>\ominus</math> dans le sens inverse des aiguilles d'une montre à partir du point nul et ajuster jusqu'à ce que la forme d'onde (signal d'erreur d'alignement) atteigne l'amplitude maximale (voir Photo 10-3).</li> </ul> <p>Remarque: Agir avec précaution car une insertion forcée du tournevis <math>\ominus</math> provoquera un flottement du capteur vers le haut.</p> <ul style="list-style-type: none"> <li>● Finalement, confirmer qu'il n'y a pas de fluctuation importante dans la tension c-c du signal d'erreur d'alignement (ne insérer le filtre passe-bas de coupure à 4 kHz) quand le capteur est déplacé vers la périphérie intérieure et vers la périphérie extérieure.</li> </ul> <p>Si l'on constate une différence supérieure à <math>\pm 10\%</math> tourner à nouveau le vis d'ajustement de grille et ajuster le signal d'erreur d'alignement au point d'amplitude maximale.</p>
	0,5V/div	5 ms/div	TP1 Broche 2 (TRK.ERR)	Grille  Grille	Point nul  Amplitude maximale	

N° d'étape	Réglage d'oscilloscope		Points d'essai	Points de réglage	Postes de contrôle/Spécifications de réglage	Procédure de réglage
	V	H				
<b>6 Ajustement d'équilibre d'alignement</b>						
	0,5V/div	5 ms/div	TP1 Broche 2 (TRK.ERR)	VR5 (TRK.BAL)		<ul style="list-style-type: none"> <li>● Installer le disque d'essai.</li> <li>● Régler l'appareil en mode d'essai (voir page 50).</li> <li>● Appuyer sur la touche MANUAL SEARCH FWD (▷) pour amener le cap-teur près du centre du disque.</li> <li>● Appuyer sur les touches TRACK FWD (▷) et PLAY (▷) en séquence pour faire tourner le disque.</li> <li>● Observer la forme d'onde de TP1 broche 2 TRK.ERR (erreur d'alignement) sur l'oscilloscope et ajuster VR5 TRK.BAL (équilibrage d'alignement) pour éliminer les éléments CC du signal d'erreur d'alignement.</li> </ul>
						
	Photo 10-4 Eléments CC mêlés au signal			Photo 10-5 Eléments CC éliminés		
<b>7 Ajustement tangentiel</b>						
					<ul style="list-style-type: none"> <li>● Régler l'appareil au mode d'essai (voir page 50).</li> <li>● Ouvrir le plateau et installer le disque d'essai.</li> <li>● Appuyer sur la touche MANUAL SEARCH FWD (▷) pour amener le cap-teur près du centre du disque.</li> <li>● Insérer une clé hexagonale dans la section de la vis d'ajustement tangentiel par l'arrière du mécanisme.</li> <li>● Refermer le plateau.</li> </ul> <p>Remarque: Ne pas se servir d'une clé hexagonale en L, mais d'une clé, comme illustré sur la gauche. Si une clé hexagonale en L est à utiliser, le plateau doit être déposé avant d'effectuer l'ajustement (voir page 39 "5. Ajustement de grille (1)").</p> <ul style="list-style-type: none"> <li>● Appuyer sur les touches TRACK FWD (▷), PLAY (▷) et PAUSE en séquence pour fermer tous les servos (le témoin PAUSE s'allume).</li> </ul>	
						
	Fig. 10-11					



N° d'étape	Réglage d'oscilloscope		Points d'essai	Points de réglage	Postes de contrôle/Spécifications de réglage	Procédure de réglage
	V	H				
		200 ms/div	TP1 Broche 1 (Sortie RF)	Vis d'ajustement tangentiel	Mire la plus nette possible	<ul style="list-style-type: none"> <li>Observer la forme d'onde de TP1 broche 1 (Sortie RF) sur l'oscilloscope et agir sur la vis d'ajustement tangentiel pour obtenir la mire la plus nette possible.</li> <li>Le point où la vis d'ajustement doit être amenée se trouve à environ mi-course entre les points où la mire est la plus floue quand la vis est tournée dans le sens des aiguilles d'une montre et dans le sens contraire. Quand toute la forme d'onde devient claire, se concentrer sur la netteté des lignes fines, formant le losange au centre de la mire (voir Photo 10-8). Ajuster jusqu'à ce que les lignes fines sur tous les quatre côtés du losange soient bien définies et denses.</li> </ul>  <p style="text-align: center;">Fig. 10-12</p> <p>Remarque: Se servir d'une clé hexagonale pour lever légèrement le capteur pendant cet ajustement.</p>

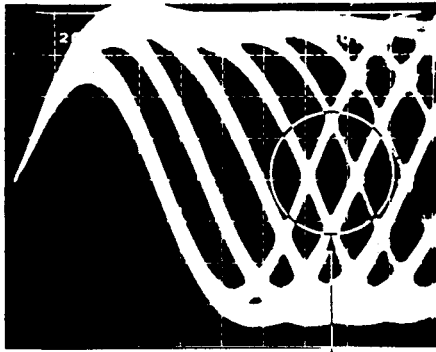

P Partie à observer

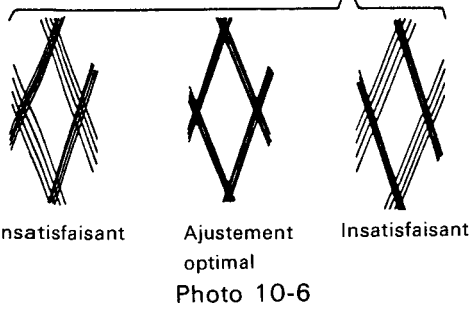

Photo 10-6



Photo 10-7

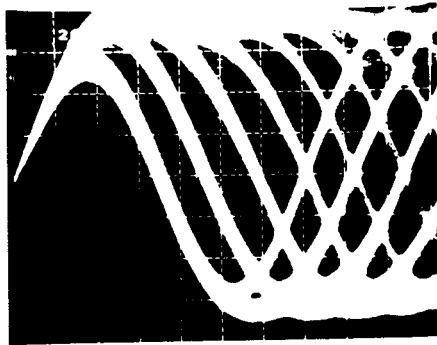

Photo 10-8



Photo 10-9

N° d'étape	Réglage d'oscilloscope		Points d'essai	Points de réglage	Postes de contrôle/Spécifications de réglage	Procédure de réglage
	V	H				
<b>8 Ajustement de gain de mise au point</b>						
	CH1(X), CH2(Y) 20 mV/div 5 mV/div (sonde: 10:1)	Axe des X TP1 Broche 5 (FCS.IN) AXE des Y TP1 Broche 6 (FCS.ERR)	VR3 (FCS.GAN)	Différence de phase de 90°	<ul style="list-style-type: none"> <li>• L'alimentation de l'oscillateur étant coupée (OFF), raccorder l'oscilloscope et l'oscillateur, comme illustré sur la Fig. 10-13.</li> <li>• Régler l'appareil en mode d'essai (voir page 50).</li> <li>• Appuyer sur les touches TRACK FWD (▶), PLAY (▷) et PAUSE (⏸) en séquence pour fermer les servos de mise au point, d'axe et d'alignement.</li> <li>• Mettre l'oscillateur sous tension (ON) et le régler pour fournir un signal de 1,2 kHz 1 V<sub>c-c</sub>.</li> </ul> <p>Remarque: Certains oscillateurs déchargent une tension CC lors de leur mise sous tension. Par conséquent, il est conseillé de connecter l'oscillateur après l'avoir mis sous tension.</p> <ul style="list-style-type: none"> <li>• Ajuster VR3 FCS.BAN (gain de mise au point) de sorte que la figure de Lissajou devienne un cercle horizontal sur l'oscilloscope (différence de phase de 90°).</li> </ul>	<p>Fig. 10-13</p>
<div style="display: flex; justify-content: space-around;"> <div style="text-align: center;"> <p>Gain sur-compensé Photo 10-10</p> </div> <div style="text-align: center;"> <p>Gain optimal Photo 10-11</p> </div> <div style="text-align: center;"> <p>Gain sous-compensé Photo 10-12</p> </div> </div>						

N° d'étape	Réglage d'oscilloscope		Points d'essai	Points de réglage	Postes de contrôle/Spécifications de réglage	Procédure de réglage
	V	H				

**9 Ajustement de gain d'alignement**

	CH1(X), CH2(Y) 50 mV/div, 5 mV/div (sonde: 10:1)	Axe des X TP1 Broche 3 (TRK.IN) AXE des Y TP1 Broche 2 (TRK.OUT)	VR4 (TRK.GAN)	Différence de phase de 90°	<ul style="list-style-type: none"> <li>• L'alimentation de l'oscillateur étant coupée (OFF), raccorder l'oscilloscope et l'oscillateur, comme illustré sur la Fig. 10-14.</li> <li>• Régler l'appareil en mode d'essai (voir page 50).</li> <li>• Appuyer sur les touches TRACK FWD (▷), PLAY (▷) et PAUSE (⊞) en séquence pour fermer les servos de mise au point, d'axe et d'alignement.</li> <li>• Mettre l'oscillateur sous tension (ON) et le régler pour fournir un signal de 1,2 kHz 2 Vc-c.</li> </ul> <p>Remarque: Certains oscillateurs déchargent une tension CC lors de leur mise sous tension. Par conséquent, il est conseillé de connecter l'oscillateur après l'avoir mis sous tension.</p> <ul style="list-style-type: none"> <li>• Ajuster VR4 TRK.BAN (gain d'alignement) de sorte que la figure de Lissajou devienne un cercle horizontal sur l'oscilloscope (différence de phase de 90°).</li> </ul>
--	--	---	------------------	----------------------------	---

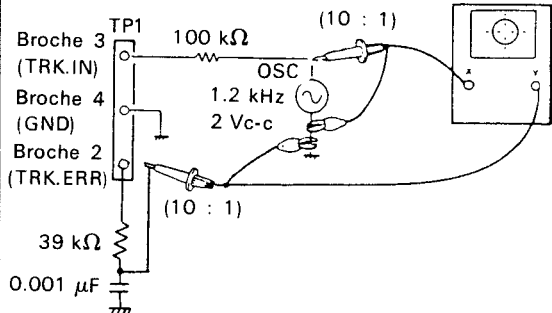
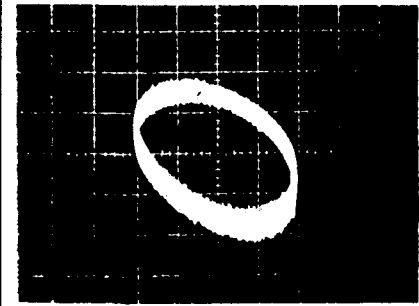
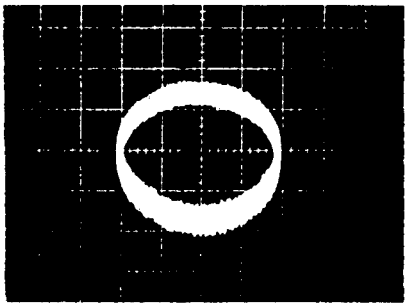

Fig. 10-14



Gain sur-compensé  
Photo 10-13



Gain optimal  
Photo 10-14

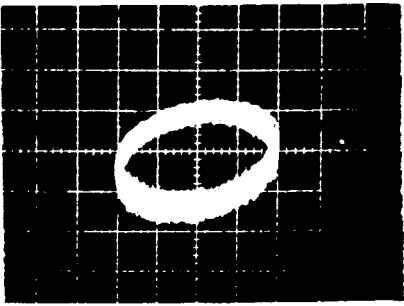

Gain sous-compensé  
Photo 10-15

N d'étape	Réglage d'oscilloscope		Points d'essai	Points de réglage	Postes de contrôle/ Spécifications de réglage	Procédure de réglage
	V	H				
10	<b>Ajustement de fréquence libre VCO</b>					
			TP2 Broche 2	VR8 (VCO.ADJ)	4.275 ±0,025 MHz	<ul style="list-style-type: none"> <li>Régler l'appareil en mode d'essai (voir page 50).</li> <li>Court-circuiter les cavaliers de l'ensemble (ASY) et de masse (GND) à l'aide d'un tournevis <math>\ominus</math> ou d'un outil analogue (voir Fig. 10-15).</li> <li>Raccorder un fréquencemètre capable de mesurer des fréquences de 10 MHz et au-delà, sur TP2 broche 2.</li> <li>Ajuster VR8 VCO.ADJ (ajustement libre VCO) de sorte que la lecture du fréquencemètre devienne <math>4.275 \pm 0,025</math> MHz.</li> </ul>
11	<b>Vérification d'erreur de mise au point</b>					
			TP1 Broche 6 (FCS.ERR)			<ul style="list-style-type: none"> <li>Régler l'appareil en mode d'essai (voir page 50)</li> <li>Mettre TP1 broche 5 FCS.IN (gain de mise au point) à la masse (GND).</li> <li>Observer la forme d'onde de TP1 broche 6 FCS.ERR (erreur de mise au point) quand la touche TRACK FWD (&gt;&gt;) est actionnée.</li> </ul>

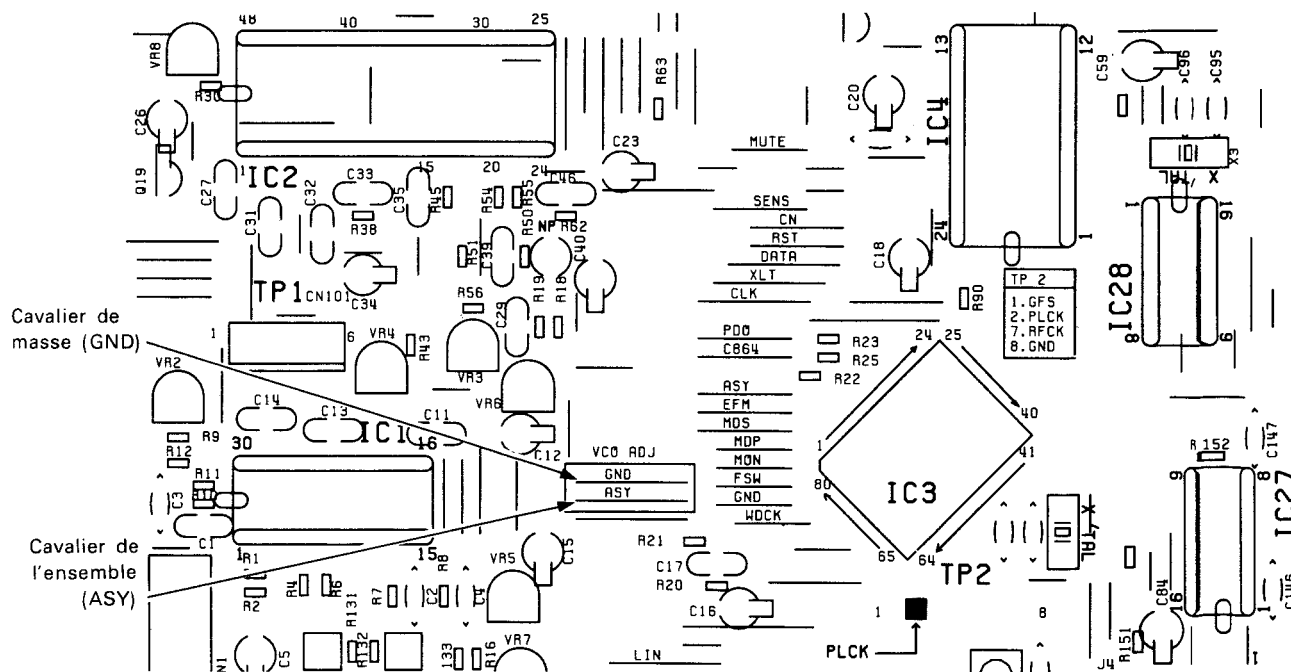
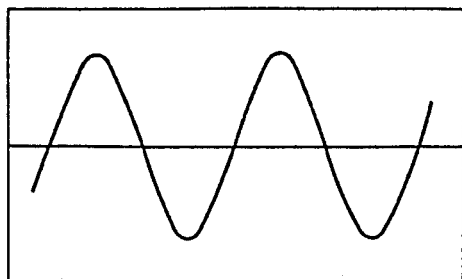

Fig. 10-15 Position des cavaliers ASY et GND

N° d'étape	Réglage d'oscilloscope		Points d'essai	Points de réglage	Postes de contrôle/Spécifications de réglage	Procédure de réglage
	V	H				
12	<b>Ajustement MBS</b>					
	5 mV/div	0.2 ms/div	Borne de sortie de ligne (LINE OUT) JA1 (canal gauche)	VR10	Onde sinusoïdale	<ul style="list-style-type: none"> <li>● Régler l'appareil en mode d'essai (voir page 36).</li> <li>● Reproduire la 20ème plage (-60 dB, 1 kHz, canal G/D) du disque d'essai (YEDS-7). Raccorder un oscilloscope au canal gauche des bornes de sortie de ligne (LINE OUT) et observer la forme d'onde de sortie audio.</li> <li>● Ajuster VR10 MSB.ADJ Rch (ajustement MBS, canal droit) pour que la forme d'onde sur l'oscilloscope devienne sinusoïdale.</li> <li>● Effectuer le même ajustement pour le canal gauche (VR9).</li> </ul>
			Borne de sortie de ligne (LINE OUT) JA1 (canal droit)	VR9	Onde sinusoïdale	

● Forme d'onde de ligne horizontale nulle



OK

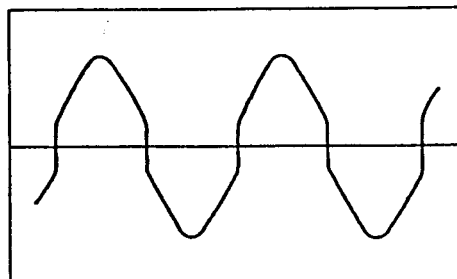

NG

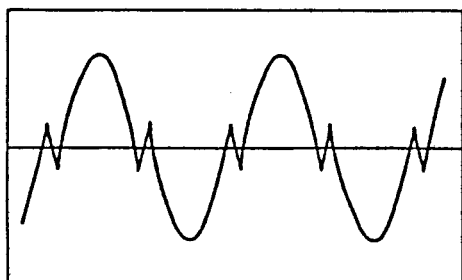

NG

## 10. AJUSTE

A continuación se ofrecen los ajustes para esta unidad. Los ajustes deberán realizarse en el orden indicado

### ● AJUSTES

1. Ajuste de la desviación del error de seguimiento, desviación de enfoque y desviación de RF.
2. Ajuste del nivel de RF
3. Comprobación de la energía del diodo láser (LD)
4. Comprobación de la sincronización del foco y del eje
5. Ajuste de retícula
6. Ajuste del equilibrio de seguimiento
7. Ajuste tangencial
8. Ajuste de la ganancia de enfoque
9. Ajuste de la ganancia de seguimiento
10. Ajuste de la frecuencia de oscilación libre del oscilador controlado por tensión (VCO)
11. Comprobación del error de enfoque
12. Ajuste de MSB

### ● EQUIPOS REQUERIDOS

1. Osciloscopio de doble traza
2. Medidor de energía óptica
3. Disco de prueba (YEDS-7)
4. Filtro de ajuste de ganancia de bucle
5. Generador de señales
6. Frecuencímetro
7. Otros equipos de medición de uso normal

### ● ACERCA DEL MODO DE PRUEBA

Todos los ajustes deberán efectuarse con la unidad en el modo de prueba.

#### Activación y desactivación del modo de prueba

- (1) Para activar el modo de prueba, ponga en ON el interruptor de la alimentación (S301) con el interruptor de modo de prueba (S1) en la posición ON.
- (2) El modo de prueba se desactiva poniendo el interruptor de la alimentación en OFF.

Las funciones de las teclas en el modo de prueba se describen en la tabla 10-1.

### ● RESISTORES VARIABLES (VR) DE AJUSTE Y SUS NOMBRES

- VR1: Energía láserica  
 VR2: Desviación de RF (RF.OFS)  
 VR3: Ganancia de enfoque (FCS.GAN)  
 VR4: Ganancia de seguimiento (TRK.GAN)  
 VR5: Equilibrio de seguimiento (TRK.BAL)  
 VR6: Desviación de enfoque (FCS.OFS)  
 VR7: Desviación de seguimiento (TRK.OFS)  
 VR8: Ajuste del VCO (VCO.ADJ)  
 VR9: Ajuste de MSB del canal derecho (MSB.ADJ-R)  
 VR10: Ajuste de MSB del canal izquierdo (MSB.ADJ-L)

#### Punto de ajuste

ENSEMBLE DE PLAQUETTE PRINCIPALE

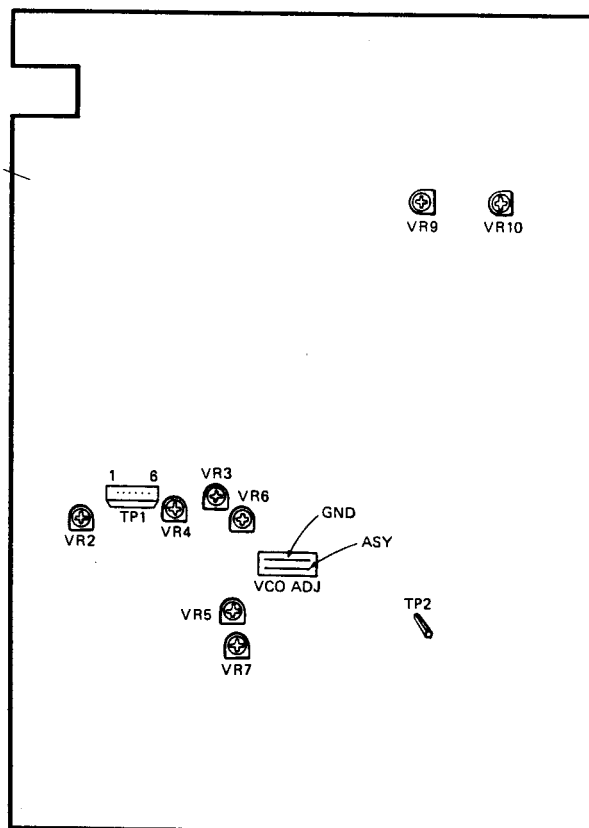

En el modo de prueba, los servos deberán cerrarse y abrirse individualmente. Por consiguiente, los servos deberán cerrarse en la secuencia apropiada (secuencia en serie) a fin de poner el aparato en el modo de reproducción. Tenga en cuenta además que durante el modo de prueba el aparato no entrará en el modo de reproducción cuando haya presionado la tecla PAUSE (■).

Por ejemplo, para cambiar del modo de parada al de reproducción tendrá que presionar las teclas de función en el orden siguiente:

\* En el modo de prueba, los servos deberán operarse en la secuencia en serie

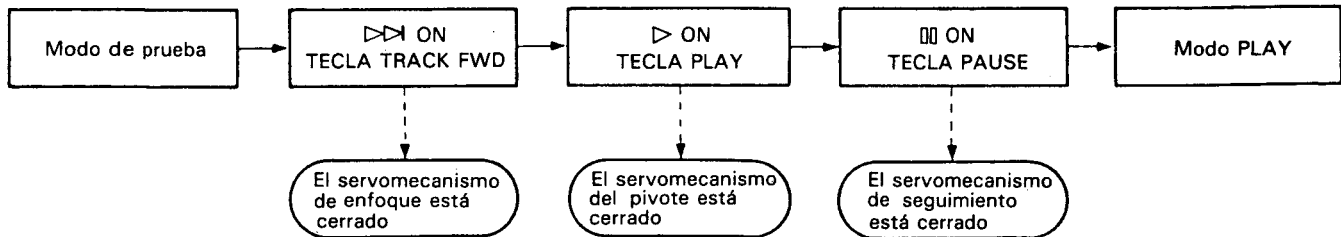

● FUNCIONES DE LAS TECLAS EN EL MODO DE PRUEBA

Símbolo	Nombre de la tecla	Función en el modo de prueba	Descripción
▷◁	TRACK FWD	Cierre del servo de enfoque	Activa el diodo láser y eleva y hace descender el actuador de enfoque para cerrar el servo de enfoque.
▷	PLAY	Cierre del servo del eje	Cierra el servo en el modo CLV-A después de impulsar el motor del eje.
■	PAUSE	Cierre/apertura del servo de seguimiento	Actúa como conmutador: cierra el servo de seguimiento y activa el modo de reproducción cuando se presiona (suponiendo que los servos de enfoque y del eje estén cerrados), momento en el que se encenderá el indicador PAUSE; y abre el servo de seguimiento cuando vuelve a presionarse.
◁▷	MANUAL SEARCH REV	Retroceso del carro (se mueve hacia adentro)	Mueve el carro rápidamente (3 cm/s) hacia la pista más interior. Tenga cuidado para no moverlo demasiado ya que no hay dispositivo de seguridad para parar el carro.
▷◁	MANUAL SEARCH FWD	Avance del carro (mueve el carro hacia afuera)	Mueve el carro rápidamente (3 cm/s) hacia la pista más exterior. tenga cuidado para no moverlo demasiado ya que no hay dispositivo de seguridad para parar el carro.
□	STOP	Parada	Para todos los servos y devuelve el sistema a su estado inicial.
⏏	OPEN/CLOSE	Apertura/cierre de la bandeja del disco	Abre y cierra la bandeja del disco. Sin embargo, el captor no regresa a su soporte en OPEN y permanece estacionario en CLOSE.

Tabla 10-1

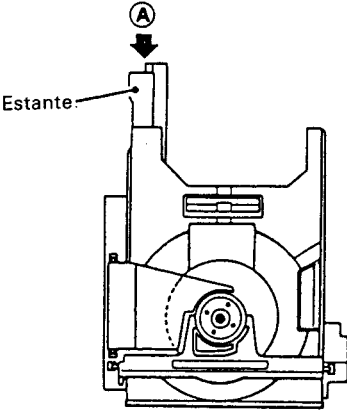
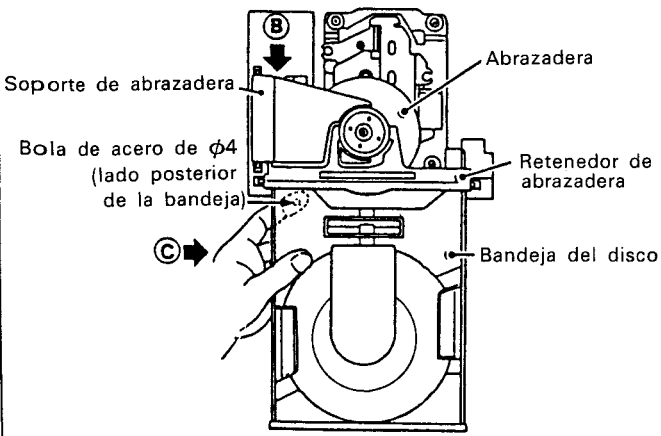

N.º de paso	Ajuste de osciloscopio		Puntos de prueba	Puntos de ajuste	Ítems de comprobación/ especificaciones de ajuste	Procedimiento de ajuste
	V	H				
<b>1 Ajuste de la desviación del error de seguimiento, desviación de enfoque y desviación de RF</b>						
			TP1 Patilla 2 (TRK.ERR)	VR5 (TRK.BAL) VR7 (TRK.OFS)	Desviación del error de seguimiento 45° 0V±50 mV	<ul style="list-style-type: none"> <li>• Ponga la unidad en el modo de prueba (consulte la página 65).</li> <li>• Ponga VR5 TRK.BAL (equilibrio de seguimiento) en una posición aproximadamente 45° a la izquierda del centro.</li> <li>• Ajuste VR7 TRK.OFS (desviación de seguimiento) de forma que la tensión TRK.ERR (error de seguimiento) en la patilla 2 de TP1 sea de 0V±50 mV.</li> <li>• Ajuste VR6 FCS.OFS (desviación de enfoque) de forma que la tensión de FCS.ERR (error de enfoque) en la patilla 6 de TP1 sea de 0V±50 mV.</li> <li>• Ajuste VR2 RF.OFS (desviación de RF) de forma que la tensión de salida de RF en la patilla 1 de TP1 sea de 100 mV±50 mV.</li> </ul> <p>Nota: Cuando ajuste la desviación del error de seguimiento, realice siempre "6. Ajuste del equilibrio de seguimiento."</p>
			TP1 Patilla 6 (FCS.ERR) TP1 Patilla 1 (RF. OUTPUT)	VR6 (FCS.OFS)  VR2 (RF.OFS)	Desviación de enfoque 0V±50mV Desviación de RF 100 mV±50 mV	
<b>2 Ajuste del nivel de RF</b>						
			TP1 Patilla 1 (RF OUTPUT)	VR1 (Energía láserica)	1.8V±0.1V	<ul style="list-style-type: none"> <li>• Ponga la unidad en el modo de prueba (consulte la página 65).</li> <li>• Reproduzca el disco de prueba, conecte el osciloscopio en la patilla 1 de TP1 (salida de RF) y mida la tensión P-P de la forma de onda de RF.</li> <li>• Compruebe si la tensión es de 1.8V±0.1V.</li> </ul>
<b>3 Comprobación de la energía del diodo láser (LD)</b>						
					Menos de 0,13 mW	<ul style="list-style-type: none"> <li>• Ponga la unidad en el modo de prueba (consulte la página 65).</li> <li>• Presione la tecla TRACK FWD (→) para activar el diodo láser (LD).</li> <li>• Coloque el sensor del medidor de energía óptica directamente sobre el objetivo y confirme si la energía del LD es inferior a 0,13 mW.</li> </ul>

N.º de paso	Ajuste de osciloscopio		Puntos de prueba	Puntos de ajuste	Ítems de comprobación/ especificaciones de ajuste	Procedimiento de ajuste
	V	H				
<b>4 Comprobación de la sincronización del foco y del eje</b>						
	V 0,5V/div	H 100 mseg/div	TP1 Patilla 1 (salida de RF)		La señal de RF sale  Giro en sentido de avance (hacia la derecha)	<ul style="list-style-type: none"> <li>• Instale el disco de prueba.</li> <li>• Ponga la unidad en el modo de prueba (consulte la página 65).</li> <li>• Presione la tecla MANUAL SEARCH FWD (▷) para mover el captor hacia el centro del disco.</li> <li>• Observe la salida de la patilla 1 de TP1 (salida de RF) en el osciloscopio. Compruebe si la señal de RF sale después de presionar la tecla TRACK FWD (▷).</li> <li>• Presione la tecla (PLAY) y compruebe si el disco gira a una velocidad constante (aproximadamente 300 r.p.m. cerca del centro del disco) en sentido de avance (hacia la derecha); cerciórese de que el disco no gire demasiado rápido ni hacia la izquierda.</li> </ul>
<b>5 Ajuste de retícula (1)</b>						
	 <p>Figura 10-1.</p>				<p>Antes de hacer este ajuste, extraiga la bandeja del disco.</p> <ul style="list-style-type: none"> <li>• <b>Extracción de la bandeja del disco.</b></li> </ul>	
	 <p>Figura 10-2.</p>				<ol style="list-style-type: none"> <li>1. Presione el borde posterior del bastidor, marcado con A en la figura 10-1., mientras tira de la bandeja del disco hacia afuera hasta la posición en la que agarre, mostrada en la figura 10-2. (*1) Cuando presione la sección trasera del bastidor (flecha A) empieza a liberarse la abrazadera del disco. Para deslizar completamente hacia afuera la bandeja del disco, continúe presionando hasta que se libere la abrazadera.</li> <li>2. Tirando del soporte de abrazadera B (consulte la figura 10-2.) hacia arriba con la mano derecha, sujete la bandeja como se indica en C con la mano izquierda y tire de ella hacia afuera. Tenga cuidado de que no caiga la bola de acero de <math>\phi 4</math> (recomendamos sujetar la bola en su lugar con el dedo índice de la mano izquierda al sacar la bandeja).</li> </ol>	

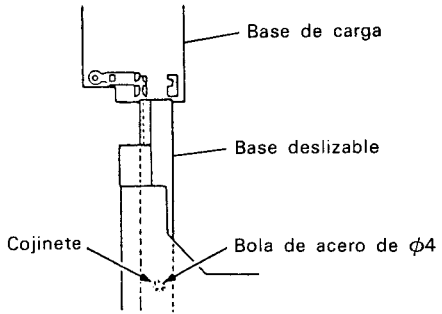
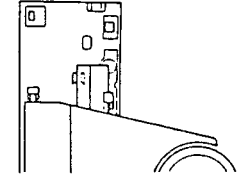

N. de paso	Ajuste de osciloscopio		Puntos de prueba	Puntos de ajuste	Ítemes de comprobación/ especificaciones de ajuste	Procedimiento de ajuste
	V	H				
	0,5V/div	5 mseg/div	TP1 Patilla 2 (TRK. ERR)	Tornillo de ajuste de retícula Tornillo de ajuste de retícula	Punto nulo  Amplitud máxima	<ul style="list-style-type: none"> <li>Gire el tornillo de ajuste de retícula con el destornillador de punta plana para encontrar el punto nulo (consulte la fotografía 10-1.).</li> <li>A continuación, gire lentamente el tornillo hacia la izquierda y ajuste hasta llegar al punto en que la onda de onda (señal de error de seguimiento) alcance por primera vez su amplitud máxima (consulte la fotografía 10-3.).</li> </ul> <p>Nota: Evite presionar sobre el destornillador mientras ajusta el tornillo. De lo contrario, el captor se moverá hacia adentro haciendo más difícil el ajuste.</p> <ul style="list-style-type: none"> <li>Para finalizar, quite el filtro de paso bajo y confirme que la tensión p-p de la señal de error de seguimiento no cambie considerablemente cuando mueva el fonocaptor hacia las pilas más interiores y exteriores del disco.</li> </ul> <p>Si el nivel cambia en <math>\pm 10\%</math> o más, vuelva a ajustar el punto de amplitud máxima de error girando el tornillo de ajuste de retícula.</p>
 <p>Figura 10-7.</p>  <p>Figura 10-8.</p>						<p>Una vez finalizado el ajuste de retícula, vuelva a montar la bandeja del disco de acuerdo con el procedimiento siguiente:</p> <ol style="list-style-type: none"> <li>Extraiga el disco y el separador.</li> <li>Levantando el sujetador de abrazadera (marcada con <b>B</b> en la figura 10-2.) con la mano derecha, sujete la bandeja con la mano izquierda como se indica en <b>C</b> y deslice la base deslizable en los acopladores de resina rígida de la base de carga como se muestra en la figura 10-7. para reinsertar la bandeja del disco.</li> </ol> <p>En este momento, asegúrese de sujetar la bola de acero de <math>\phi 4</math> en su lugar con el dedo índice de la mano izquierda.</p> <p>Además, tenga cuidado para no dañar el panel frontal con el cojinete de la base deslizable, en la sección de la bola de acero de <math>\phi 4</math> que entra en contacto con el panel.</p> <ol style="list-style-type: none"> <li>Inserte la base deslizable de forma que encaje en los dos acopladores de resina rígida de la parte posterior de la base de carga (consulte la figura 10-8.).</li> <li>Inserte completamente la bandeja del disco.</li> </ol>

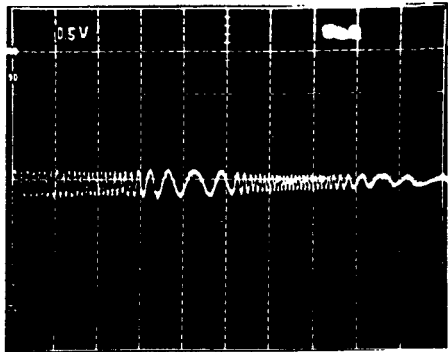

Fotografía 10-1. Punto nulo

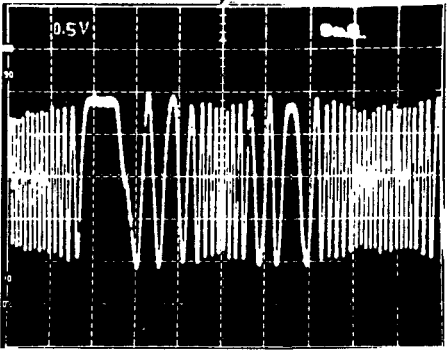

Fotografía 10-3. Amplitud máxima

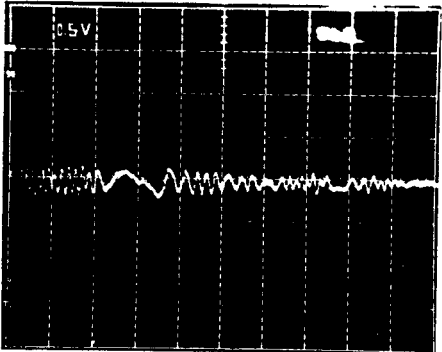

Fotografía 10-2. Esta no es la forma de onda de punto nulo

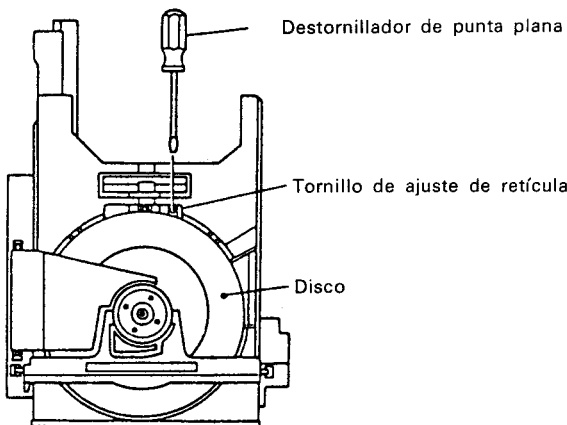
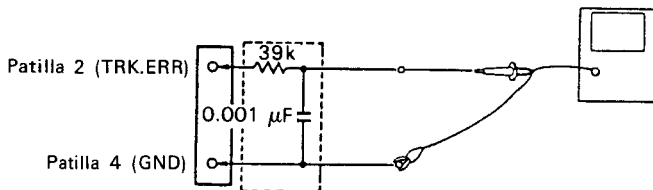
N.º de paso	Ajuste de osciloscopio		Puntos de prueba	Puntos de ajuste	Ítems de comprobación/especificaciones de ajuste	Procedimiento de ajuste
	V	H				
5	<b>Ajuste de retícula (2) (empleando discos con una duración de reproducción de 60 minutos o más)</b>					
	 <p>Destornillador de punta plana</p> <p>Tornillo de ajuste de retícula</p> <p>Disco</p>			<p>Nota: Este ajuste podrá realizarse solamente con un disco que tenga hoyos de hasta R115 mm, no con el disco de prueba (YEDS-7).</p> <ul style="list-style-type: none"> <li>• Ponga la unidad en el modo de prueba (consulte la página 65).</li> <li>• Instale el disco de prueba, desplace el captor hacia la pista exterior de forma que el orificio de ajuste de retícula del captor quede visible desde la superficie de hoyos del disco o a través del agujero del mecanismo de servos (consulte la figura 10-9).</li> <li>• Presione las teclas TRACK FWD (▷▷) y PLAY (▷) en secuencia para cerrar los servos de enfoque y del eje (no cierre el servo de seguimiento).</li> <li>• Observe la salida de la forma de onda de TRK.ERR (error de seguimiento) de la patilla 2 de TP1 en un osciloscopio, insertando un filtro de paso bajo de 4 kHz (consulte la figura 10-10).</li> </ul>		
	 <p>Patilla 2 (TRK.ERR)</p> <p>39k</p> <p>0.001 µF</p> <p>Patilla 4 (GND)</p>			<p>Figura 10-9.</p> <p>Figura 10-10.</p>		
0,5V/div	5 mseg/div	TP1 Pastilla 2 (TRK.ERR)	Retícula	Punto nulo	<ul style="list-style-type: none"> <li>• Inserte un destornillador de punta plana en el agujero de retícula, gire el destornillador y encuentre el punto nulo (consulte la fotografía 10-1.).</li> <li>• A continuación, gire lentamente el destornillador de punta plana hacia la izquierda desde el punto nulo y ajuste hasta que la forma de onda (señal de error de seguimiento) alcance la máxima amplitud (consulte la fotografía 10-3.).</li> <li>• Tenga cuidado porque si inserta el destornillador de punta plana a la fuerza el captor se elevará.</li> <li>• Finalmente, confirme que no haya una gran fluctuación de la tensión p-p de la señal de error de seguimiento (no inserte el filtro de paso bajo de 4kHz de corte) cuando el captor se desplace hacia la pista más interior del disco. Si la diferencia es mayor del ±10%, gire de nuevo el tornillo de ajuste de retícula y ajuste la señal de error de seguimiento al punto de amplitud máximo.</li> </ul>	
			Retícula	Amplitud máxima		

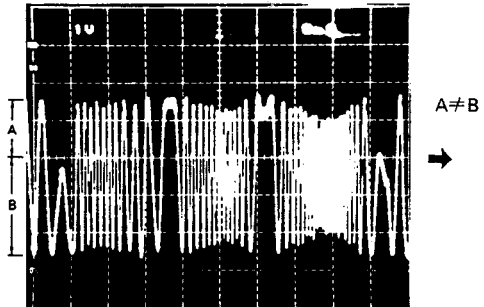
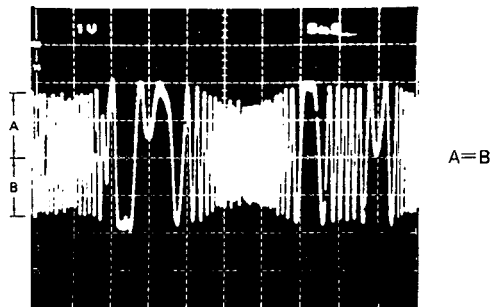
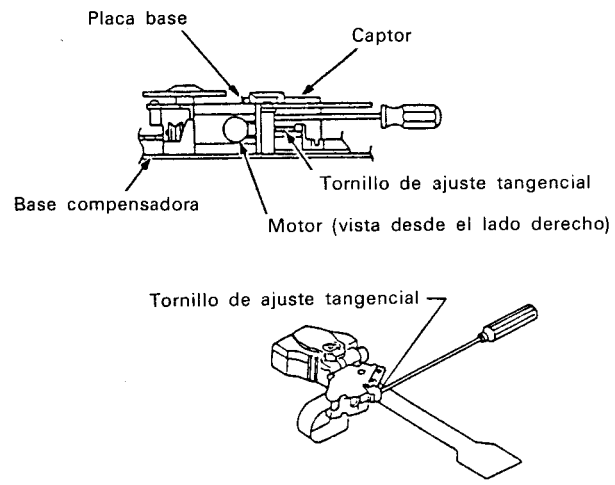
N. de paso	Ajuste de osciloscopio		Puntos de prueba	Puntos de ajuste	Ítems de comprobación/ especificaciones de ajuste	Procedimiento de ajuste
	V	H				
<b>6 Ajuste del equilibrio de seguimiento</b>						
	0,5V/div	5 mseg/div	TP1 Patilla 2 (TRK.ERR)	VR5 (TRK.BAL)		<ul style="list-style-type: none"> <li>• Instale el disco de prueba</li> <li>• Ponga la unidad en el modo de prueba (consulte la página 65).</li> <li>• Presione la tecla MANUAL SEARCH FWD (▷) para colocar el captor cerca del centro del disco.</li> <li>• Presione secuencialmente las teclas TRACK FWD (▷) y PLAY (▷) para que gire el disco.</li> <li>• Observe la salida de la forma de onda de TRK.ERR (error de seguimiento) de la patilla 2 de TP1 en el osciloscopio y ajuste VR5 TRK.BAL (equilibrio de seguimiento) para eliminar los componentes de CC de la señal de error de seguimiento.</li> </ul>
						
	Fotografía 10-4. Elementos de CC mezclados en la señal				Fotografía 10-5. Elementos de CC eliminados	
<b>7 Ajuste tangencial</b>						
					<ul style="list-style-type: none"> <li>• Ponga la unidad en el modo de prueba (consulte la página 65).</li> <li>• Abra la bandeja e instale el disco de prueba.</li> <li>• Presione la tecla MANUAL SEARCH FWD (▷) para poner el captor cerca del centro del disco.</li> <li>• Inserte una llave hexagonal en la sección del tornillo de ajuste tangencial desde la parte posterior del mecanismo.</li> <li>• Cierre la bandeja.</li> </ul> <p>Nota: No emplee una llave hexagonal en forma de L. Emplee una como la mostrada a la izquierda. Si emplea una llave hexagonal en forma de L tendrá que retirar la bandeja antes de realizar el ajuste (consulte la página 39, "5. Ajuste de retícula (1))."</p> <ul style="list-style-type: none"> <li>• Presione secuencialmente las teclas TRACK FWD (▷), PLAY (▷) y PAUSE para cerrar todos los servos (el indicador de pausa se encenderá).</li> </ul>	
	Figura 10-11.					

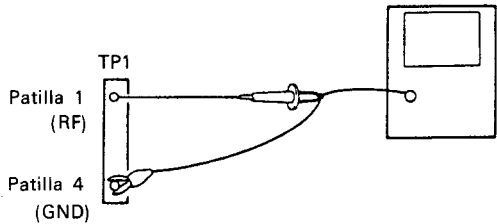
N. de paso	Ajuste de osciloscopio		Puntos de prueba	Puntos de ajuste	Ítems de comprobación/ especificaciones de ajuste	Procedimiento de ajuste
	V	H				
		200 mseg/div	TP1 Patilla 1 (Salida de RF)	Tornillo de ajuste tangencial	Patrón ocular más nítido posible	<ul style="list-style-type: none"> <li>Observe la salida de la forma de onda de la patilla 1 de TP1 (salida de RF) en el osciloscopio y ajuste el tornillo de ajuste tangencial hasta lograr el patrón ocular más nítido posible.</li> <li>El punto en el que el tornillo de ajuste tendrá que quedar está aproximadamente en la mitad de los puntos en los que el patrón ocular se vuelve más borroso al girar dicho tornillo hacia la derecha y hacia la izquierda. Cuando toda la forma de onda sea clara, concentre o aguce las líneas finas que forman el diamante en el centro del patrón ocular (consulte la fotografía 10-8.). Ajuste hasta que las líneas finas de los cuatro lados del diamante queden nítidamente definidas y densa.</li> </ul>  <p style="text-align: center;">Figura 10-12.</p> <p>Nota: Emplee una llave hexagonal para levantar algo el captor cuando realice este ajuste.</p>



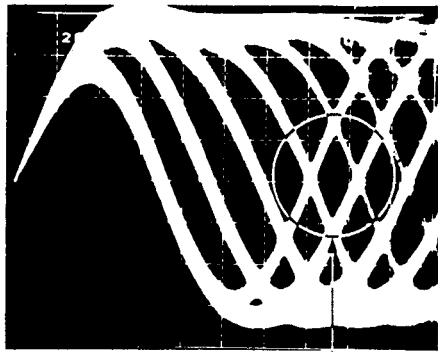

Parte que debe observar

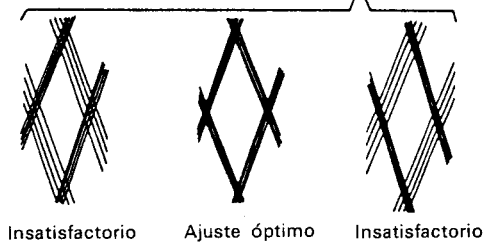

Fotografía 10-6.

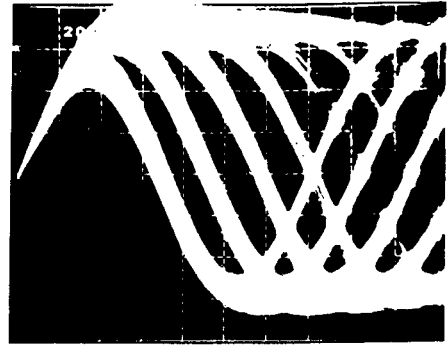

Fotografía 10-7.



Fotografía 10-8.



Fotografía 10-9.

N. de paso	Ajuste de osciloscopio		Puntos de prueba	Puntos de ajuste	Ítemes de comprobación/ especificaciones de ajuste	Procedimiento de ajuste
	V	H				
8	<b>Ajuste de ganancia de enfoque</b>					
	CH1(X), CH2(Y) 20 mV/div 5 mV/div (Sonda: 10:1)	Eje x TP1 Patilla 5 (FCS. IN) Eje Y TP1 Patilla 6 (FCS. ERR)	VR3 (FCS. GAN)	Diferencia de fase de 90°	<ul style="list-style-type: none"> <li>• Con la alimentación del oscilador desconectada, conecte el osciloscopio y el oscilador como se muestra en la figura 10-13.</li> <li>• Ponga la unidad en el modo de prueba (consulte la página 65).</li> <li>• Presione secuencialmente las teclas TRACK FWD (▶▶), PLAY (▶) y PAUSE (■) para cerrar los servos de enfoque, eje y seguimiento.</li> <li>• Conecte la alimentación del oscilador y ajuste su salida a una señal de 1,2 kHz, 1 Vp-p.</li> </ul> <p>Nota: Algunos osciladores descargan una tensión CC cuando se conecta su alimentación. Por lo tanto, se recomienda conectar el oscilador después de haber conectado su alimentación.</p> <ul style="list-style-type: none"> <li>• Ajuste VR3 FCS.GAN (ganancia de enfoque) de forma que la figura de Lissajous se convierta en un círculo horizontal en el osciloscopio (diferencia de fase de 90°).</li> </ul>	<p>Figura 10-13.</p>
						Ganancia sobrecompensada Fotografía 10-10.
						Ganancia óptima Fotografía 10-11.
						Ganancia subcompensada Fotografía 10-12.

N. de paso	Ajuste de osciloscopio		Puntos de ajuste	Puntos de prueba	Ítemes de comprobación/ especificaciones de ajuste	Procedimiento de ajuste
	V	H				
9	Ajuste de ganancia de seguimiento					
	CH1(X), CH2(Y) 50 mV/div, 5 mV/div (Sonda: 10:1)	Eje X TP1 Patilla 3 (TRK.IN) Eje Y TP1 Patilla 2 (TRK.OUT)	VR4 (TRK.GAN)	Diferencia de fase de 90°	<ul style="list-style-type: none"> <li>Con la alimentación del oscilador desconectada, conecte el osciloscopio y el oscilador como se muestra en la figura 10-14.</li> <li>Ponga la unidad en el modo de prueba (consulte la página 65).</li> <li>Presione secuencialmente las teclas TRACK FWD (➤), PLAY (▶) y PAUSE (⏸) para cerrar los servos de enfoque, eje y seguimiento.</li> <li>Conecte la alimentación del oscilador y ajuste su salida a una señal de 1,2 kHz, 2 Vp-p.</li> </ul> <p>Nota: Algunos osciladores descargan una tensión CC cuando se conecta su alimentación. Por lo tanto, se recomienda conectar el oscilador después de haber conectado su alimentación.</p> <ul style="list-style-type: none"> <li>Ajuste VR4 TRK.GAN (ganancia de seguimiento) de forma que la figura de Lissajous se convierte en un círculo horizontal en el osciloscopio (diferencia de fase de 90°).</li> </ul>	<p>Figura 10-14.</p>
						Ganancia sobrecompensada Fotografía 10-13.
						Ganancia óptima Fotografía 10-14.
						Ganancia subcompensada Fotografía 10-15.

N.º de paso	Ajuste de osciloscopio		Puntos de prueba	Puntos de ajuste	Ítems de comprobación/ especificaciones de ajuste	Procedimiento de ajuste
	V	H				
10	<b>Ajuste de frecuencia de oscilación libre del oscilador controlado por tensión (VCO)</b>					
			TP2 Patilla 2	VR8 (VCO.ADJ)	4.275 ±0,025 MHZ	<ul style="list-style-type: none"> <li>• Ponga la unidad en el modo de prueba (consulte la página 65).</li> <li>• Cortocircuite el cable de puente de ASY y GND con un destornillador de punta plana o herramienta similar (consulte la figura 10-15.).</li> <li>• Conecte un frecuencímetro capaz de medir frecuencias de 10 MHz y más a la patilla 2 de TP2.</li> <li>• Ajuste VR8 VCO.ADJ (ajuste de oscilación libre del VCO) para que la indicación del frecuencímetro sea de 4.275±0,025.</li> </ul>
11	<b>Comprobación del error de enfoque</b>					
			TP1 Patilla 6 (FCS.ERR)			<ul style="list-style-type: none"> <li>• Ponga la unidad en el modo de prueba (consulte la página 65).</li> <li>• Conecte a masa FCS.IN (entrada de enfoque) de la patilla 5 de TP1.</li> <li>• Observe la salida de forma de onda de FCS.ERR (error de enfoque) de la patilla 6 de TP1 cuando se presione la tecla TRACK FWD (&gt;&lt;).</li> </ul>



Figura 10-15. Posiciones de los cables de puente ASY y GND

N. de paso	Ajuste de osciloscopio		Puntos de prueba	Puntos de ajuste	Ítems de comprobación/ especificaciones de ajuste	Procedimiento de ajuste
	V	H				
12	<b>Ajuste de MSB</b>					
	5 mV/div	0,2 mseg/div	JA1 Terminal LINE OUT (Canal izquierdo)	VR10	Onda sinusoidal	<ul style="list-style-type: none"> <li>• Ponga la unidad en el modo de reproducción normal.</li> <li>• Reproduzca la melodía n.º 20 (-60 dB, 1 kHz, canal izquierdo/derecho (YEDS-7). Conecte un osciloscopio en el canal izquierdo de los terminales LINE OUT y observe la forma de onda de la salida de audio.</li> <li>• Ajuste VR10 MSB.ADJ Rch (ajuste de MSB, canal derecho) de forma que la forma de onda del osciloscopio sea una onda sinusoidal.</li> <li>• Realice el mismo ajuste para el canal izquierdo (VR9).</li> </ul>
			JA1 Terminal LINE OUT (Canal derecho)	VR9	Onda sinusoidal	

● Forma de onda de distorsión del eje de cruce cero

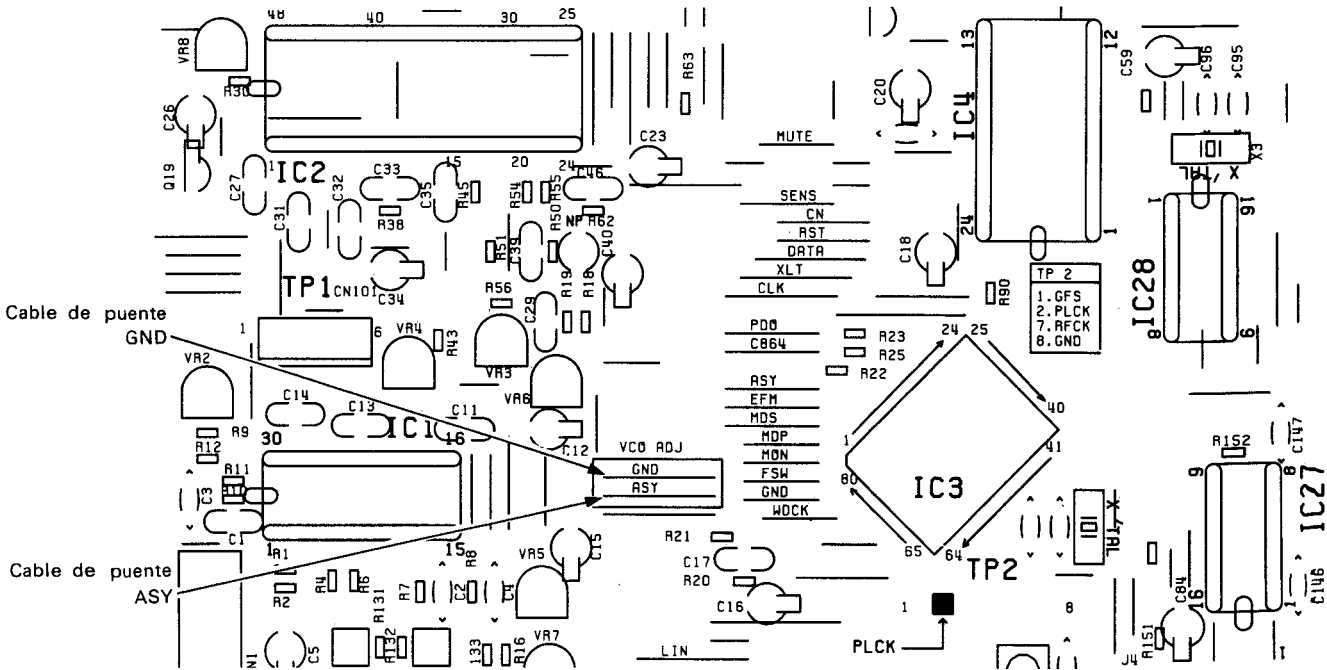
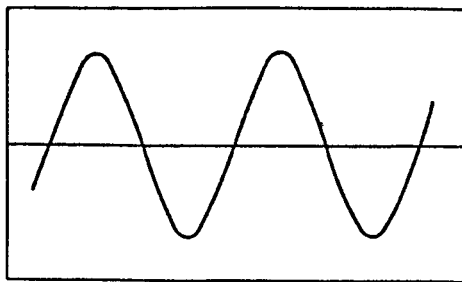

BIEN

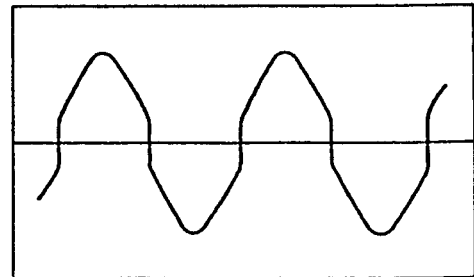

MAL

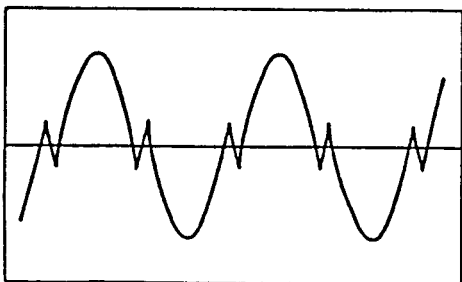

MAL

# 11. IC DESCRIPTIONS

## PD0029

Pin No.	Symbol	Name	I/O	Function
1	XIN	XIN	I	Crystal oscillation circuit input or external input
2	XOUT	XOUT	O	Crystal oscillation circuit output
3	CKS	CLOCK SELECT	I	16.9344 MHz when H 8.4672 MHz when L
4	CKOUT	CLOCK OUT	O	16.9344 MHz clock output when CKS=H 8.4672 MHz clock output when CKS=L
5	LRCK	LR CLOCK	I	LR clock input
6	DATA	DATA	I	Serial data input (compliment of 2, MSB first)
7	BCLK	BIT CLOCK	I	Bit clock input for input data
8	VSS			Ground pin
9	LCOUT	LCLOCK OUT	O	L-ch when 2 DAC used Clock output for DAC
10	SHR	SHR	O	Sample hold pulse output for R-ch
11	SHL	SHL	O	Sample hold pulse output for L-ch
12	DOUT	DATA OUT	O	Serial data output (compliment of 2, MSB first)
13	WOUT	WORD CK OUT	O	Word clock output
14	$\overline{\text{LROUT}}$	LR CK OUT	O	LR select clock output
15	BOUT	BIT CK OUT	O	Bit clock output for DOUT
16	VDD			+5V, Power supply pin

## PD4152

No.	Symbol	Name	I/O	Function	At Reset	Initial
1	S <sub>3</sub>	SEG h	O	Segment output for FL drive	-26V	-26V
2	S <sub>2</sub>	SEG g	O	Segment output for FL drive	-26V	-26V
3	S <sub>1</sub>	SEG f	O	Segment output for FL drive	-26V	-26V
4	S <sub>0</sub>	SEG e	O	Segment output for FL drive	-26V	-26V
5	P <sub>00</sub>	$\overline{\text{TEST}}$	I	Test mode selection input Test Normal	—	—
6	$\overline{\text{SCK}}$	CLK	O	Serial clock	—	H
7	SO	DATA	O	LSI control data serial output	—	H
8	SI	SUBQ	I	Sub-code Q data serial input	—	—
9	INT <sub>0</sub>	RMDT	I	Remote control data input	—	—
10	INT <sub>1</sub>	SCOR	I	Sub-code sync S <sub>0</sub> + S <sub>1</sub> output Sync	—	—
11	P <sub>12</sub>	GFS	I	Frame sync lock input NG OK	—	—
12	P <sub>13</sub>	CENS	I	LSI operation state multi-mode input	—	—
13	P <sub>20</sub>	KD0	I	Key scan input	—	—
14	P <sub>21</sub>	KD1	I	Key scan input	—	—
15	P <sub>22</sub>	KD2	I	Key scan input	—	—
16	P <sub>23</sub>	KD3	I	Key scan input	—	—
17	P <sub>30</sub>	Not used	O	NC (open)	—	L
18	P <sub>31</sub>	MUTE	O	Muting output OFF ON	—	H
19	P <sub>32</sub>	$\overline{\text{XLT}}$	O	LSI control data latch pulse	—	H
20	P <sub>33</sub>	DIRC	O	Direction reversal output for track jump	—	H
21	P <sub>60</sub>	SYC1	I	Input pin for deck syncro (pull-up when not used)	—	—
22	P <sub>61</sub>	SYC2	O	Output pin for deck syncro	—	L
23	P <sub>62</sub>	LIN	O	Disk tray loading IN	—	L
24	P <sub>63</sub>	LOUT	O	IN/OUT output Brake OUT	—	L
25	P <sub>40</sub>	$\overline{\text{OPEN}}$	I	Disk tray open completion SW input OPEN NOT	—	—
26	P <sub>41</sub>	$\overline{\text{CLMP}}$	I	Disk tray clamp completion SW input CLAMP NOT	—	—
27	P <sub>42</sub>	$\overline{\text{INSD}}$	I	Slider inside SW input INSIDE NOT	—	—
28	P <sub>43</sub>	FOK	I	Focus OK input NG OK	—	—
29	PPO	$\overline{\text{LDON}}$	O	Laser diode ON OFF output ON OFF	—	H
30	X <sub>1</sub>	—	—	Connection pin for main system clock oscillation 4.19 MHz	—	—
31	X <sub>2</sub>	—	—		—	—
32	V <sub>SS</sub>	—	—	GND		
33	XT <sub>1</sub>	—	—	GND		
34	XT <sub>2</sub>	—	—	NC		
35	P <sub>50</sub>	Not used	O	NC (open)	—	L

No.	Symbol	Name	I/O	Function	At Reset	Initial
36	P <sub>51</sub>	ALAT	O	ATT level latch pulse output	—	H
37	P <sub>52</sub>	ADAT	O	ATT level data	—	H
38	P <sub>53</sub>	ACLK	O	ATT level clock	—	H
39	$\overline{\text{RST}}$	RESET	I	CPU reset input	—	—
40	T <sub>0</sub>	DIG0	O	Digit output for FL drive	-26V	
41	T <sub>1</sub>	DIG1	O	Digit output for FL drive	-26V	
42	T <sub>2</sub>	DIG2	O	Digit output for FL drive	-26V	
43	T <sub>3</sub>	DIG3	O	Digit output for FL drive	-26V	
44	T <sub>4</sub>	DIG4	O	Digit output for FL drive	-26V	
45	T <sub>5</sub>	DIG5	O	Digit output for FL drive	-26V	
46	T <sub>6</sub>	DIG6	O	Digit output for FL drive	-26V	
47	T <sub>7</sub>	DIG7	O	Digit output for FL drive	-26V	
48	T <sub>8</sub>	DIG8	O	Digit output for FL drive	-26V	
49	T <sub>9</sub>	DIG9	O	Digit output for FL drive	-26V	
50	PH <sub>3</sub>	PASL	O	Pause LED output	—	L
51	PH <sub>2</sub>	PLYL	O	Play LED output	—	L
52	PH <sub>1</sub>	LIOL	O	Loading LED output	—	H
53	PH <sub>0</sub>	DEMP	O	De-emphasis ON/OFF output	—	-5V
54	S <sub>11</sub>	SEG.m	O	Segment output for FL drive	-26V	-26V
55	S <sub>10</sub>	SEG.l	O	Segment output for FL drive	-26V	-26V
56	V <sub>LOAD</sub>	—	—	FIP controller/driver pull-down resistor connection pin	-26V	
57	V <sub>PRE</sub>	—	—	Power pin for FIP controller/driver pre-driver	-5V	
58	S <sub>9</sub>	SEG.j	O	Segment output for FL drive	-26V	-26V
59	S <sub>8</sub>	SEG.i	O	Segment output for FL drive	-26V	-26V
60	S <sub>7</sub>	SEG.d	O	Segment output for FL drive	-26V	-26V
61	S <sub>6</sub>	SEG.c	O	Segment output for FL drive	-26V	-26V
62	S <sub>5</sub>	SEG.b	O	Segment output for FL drive	-26V	-26V
63	S <sub>4</sub>	SEG.a	O	Segment output for FL drive	-26V	-26V
64	V <sub>DD</sub>	—	—	+5V		

NOTE:

— : Hi — Imp

H; Hi-Level

L; Low-Level



## 12. REMOTE CONTROL UNIT

### Parts list

<u>Mark</u>	<u>No.</u>	<u>Part No.</u>	<u>Description</u>
	1	PAM1071	Filter
	2	PNW1151	Case (T)
	3	PNW1152	Case (B)
	4	PNW1153	Cover
	5	PWW1023	Remote control unit

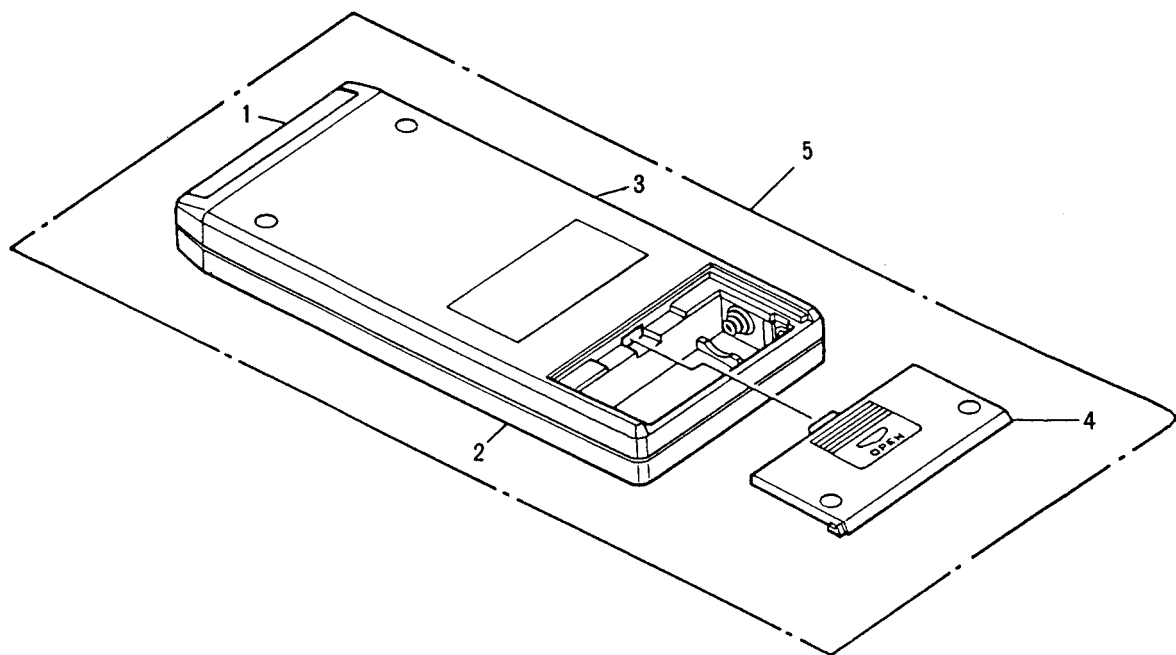

### 13. FOR HB, SD AND PD-6100-S/HEM TYPES

**NOTES :**

- Parts without part number cannot be supplied.
- The  $\Delta$  mark found on some component parts indicates the importance of the safety factor of the part. Therefore, when replacing, be sure to use parts of identical designation.
- For your parts Stock Control, the fast moving items are indicated with the marks  $\star\star$  and  $\star$ .  
 $\star\star$  GENERALLY MOVES FASTER THAN  $\star$ .
- This classification shall be adjusted by each distributor because it depends on model number, temperature, humidity, etc.
- Parts marked by "O" are not always kept in stock. Their delivery time may be longer than usual or they may be unavailable.

The PD-6100/HB, SD and PD-6100-S/HEM types are the same as the PD-6100/HEM type with the exception of the following sections.

Mark	Symbol & Description	Part No.				Remarks
		PD-6100/ HEM type	PD-6100/ HB type	PD-6100/ SD type	PD-6100-S /HEM type	
$\Delta$	AC power cord	PDG1003	PDG1004	PDG1013	PDG1003	
$\Delta \star$	Power transformer	PTT1063	PTT1063	PTT1064	PTT1063	
$\Delta\star\star$	Line voltage selector	.....	.....	PSB1002	.....	
	Name plate B	PNW1358	PNW1358	PNW1358	PNW1398	
	Knob (PHONES LEVEL)	PAC1208	PAC1208	PAC1208	PAC1271	
	Button (TRACK)	PAC1251	PAC1251	PAC1251	PAC1287	
	Button B (POWER)	PAC1252	PAC1252	PAC1252	PAC1289	
	Button C (SELECT)	PAC1253	PAC1253	PAC1253	PAC1286	
	Button D (SELECT)	PAC1254	PAC1254	PAC1254	PAC1295	
	FL Filter	PAM1232	PAM1232	PAM1233	.....	
	Button C (OPEN/CLOSE)	PAC1256	PAC1256	PAC1256	PAC1288	
	Play button B assembly	PAD1035	PAD1035	PAD1035	PAD1037	
	Function panel C	PNW1357	PNW1357	PNW1357	PNW1380	
	Bonnet	PYY1062	PYY1062	PYY1062	PYY1068	
	GND plate	.....	.....	.....	PBK1044	
	Packing case	RHG1198	RHG1198	RHG1198	RHG1200	
	Operating instruction (English)	.....	PRB1052	PRB1052	.....	
	Operating instruction (Spanish)	.....	.....	PRC1009	.....	
	Operating instruction (English, German, French, Italian)	PRE1052	.....	.....	PRE1052	
	Operating instruction (Spanish, Swedish, Dutch, Portuguese)	PRF1007	.....	.....	PRF1007	
	Lead wire unit	PDF1035	.....	PDF1041	.....	